

Effect of Process Parameters on Surface Roughness of Mild Steel Processed by Surface Grinding Process

Balwinder Singh* and Balwant Singh

Department of Mechanical Engineering, Punjab Technical University, Punjab – 151 001, India

* Corresponding author E-mail: bwssidhu@yahoo.com

Abstract - Surface grinding process is used mainly to grind flat surfaces. There are many conditions in manufacturing, where the work-piece material is either too hard or its shape is difficult to produce with sufficient accuracy by any other cutting methods, one of the best methods for producing such parts is to use abrasives. Grinding is basically a chip removal process in which the cutting tool is an individual abrasive grain. Surface grinding process cannot be efficiently carried out without the correct fluid. In the present study Horizontal spindle and reciprocating table type surface grinding machine fitted with test rig is used and cutting fluid is applied through the convergent nozzle to throw the cutting fluids at the cutting zone. This process can be utilized to create flat shapes at a high production rate and low cost. This paper investigates the effect of process parameters such as grinding wheel speed, work-piece speed and nozzle angle on the surface roughness value of mild steel specimen produced by surface grinding process. In order to evaluate the effect of selected process parameters, one variable approach has been used in the present study. Plots of various output responses have been used to determine the relationship between the output response and the input parameters. The value of surface roughness of grinded mild steel work-piece varies from 0.77 μm to 0.79 μm .

Keywords - Surface grinding process, Surface roughness, Mild steel specimen

I. INTRODUCTION

The grinding process is the material removal and surface process to shape the finish part of any materials example steel, aluminum alloys and the others. Nowadays, roughness plays a significant role in determining and evaluating the surface quality of a product as it affects the functional characteristic. The product quality depends very much on surface roughness. Decrease of surface roughness quality also leads to decrease of product quality. In field of manufacture, especially in engineering, the surface finish quality can be a considerable importance that can affects the functioning of a component, and possibly its cost.

A. Grinding Process and Grinding Fluid Applications

The grinding process is the most suitable process to obtain a very good surface finish and accuracy. Grinding developed as a metal manufacturing process in the nineteenth century. Grinding played an important role in the development of tools and in the production of steam engines, internal combustion engines, bearings, transmissions, and ultimately jet engines, astronomical instruments, and micro-electronic devices [1]. Surface grinders produce flat surfaces.

The part is held on the flat table (steel parts can be held by a magnetic force – this is called magnetic chucking). The table moves in a reciprocating motion ($\pm X$ -axis), and the rotating wheel is lowered (Z -axis) so that it just scrapes along the surface. After each reciprocating cycle, the part is fed by a small amount along the Y -axis. Surface grinding is frequently applied to match dimensional tolerance during the manufacturing of structural components. However, improper grinding can result in surface cracks and sub-surface flaws. Tawakoli *et al.*, reviewed dry grinding process as it is one of the most favorable processes from an economical as well as an ecological point of view [2]. Oliveira *et al.* analyzed relevant industrial demands for grinding research [3]. The focus was to understand the main research challenges in the extensive industrial use of the process. Kiyak *et al.*, examined and compared dry and cutting fluid application (wet) in grinding as the process is practiced to obtain the best possible surface quality and dimensionally accurate of ground machine parts [4]. The grinding parameters such as ground work-piece material, wheel type, wheel speed, work-piece speed, depth of cut and feed alter the surface finish of work-piece. The application of cutting fluid is generally carried out and the influence of selected cutting fluid on surface roughness is widely accepted positive. The selected grinding parameters such as depth of cut, feed and wheel speed showed more important factors on surface roughness. The mean size of abrasive particle used in each tool determines the rate at which it will cut, and the quality of surface finish it will provide. Cakir *et al.* analyzed that effect of friction generated heat affects shorter tool life, higher surface roughness and lowers the dimensional sensitiveness of work material [5]. They reported different methods to protect cutting tool from the generated heat during machining operations to provide lubrication and cooling effects between cutting tool and work-piece. The selection of cutting fluids should be carefully carried out to obtain optimum result in machining processes. Various factors affects the selection of cutting fluid type in machining operation such as type of work-piece materials, cutting tool material and the method of machining processes. Water was used as cutting fluid for grinding mild steel in the present study. New nozzle designs were presented that give long coherent jets, up to 45 m/s, maximizing the application of fluid into the grinding zone [6]. A principal function of fluid is to improve lubrication and subsequently reduce the risk of thermal damage and improve process performance [7]. Correct nozzle design and positioning are critical elements of the delivery system and

their research presents the initial work on nozzle design. The influence of nozzle position, jet velocity, and distance from the grinding zone was presented. A 26.5% increase in wheel life as a result of coolant application optimization during grinding of an aerospace component was reported [8].

II. PARAMETERS UNDER INVESTIGATION AND THEIR LEVELS

Using cause and effect analysis the factors which may affect the response parameters (surface roughness, dimensional control and micro hardness) with their levels were identified. Some factors like type of coolant, work-piece material, nozzle tip distance and grade of grinding wheel were kept constant during the experimental study. The various parameters like wheel speed, work-piece speeds were selected as per availability of pulley combinations on grinder.

TABLE I SELECTED PROCESS PARAMETERS AND THEIR LEVELS

Parameters	Levels		
	Level-1	Level-2	Level-3
Wheel peripheral speed (m/sec)	2800	3718	5670
Work-Table speed (m/minute)	1.5	3	4.5
Inlet pressure of coolant (kg/cm ²)	25	27	29
Nozzle angle (degrees)	6	8	12

The inlet pressures were then selected so that velocity of the fluid at the outlet maintains proper cooling. Finally the various nozzle angles were selected at which the cooling effect and nozzle efficiency is optimal as claimed by various researchers in the available literature. The internal geometry of nozzles was selected as proposed by various researchers [8]. The lists of parameters studied with their levels are shown in the Table I. The experimental layout for the grinding parameters is shown in Table II.

III. EXPERIMENTAL DETAILS

The experiments have been conducted on modified surface grinding machine (Make: HMT; Model: (GTC- 28) available at Central Workshop, PTU GZS Campus, Bathinda. The speeds of wheel were changed by changing the position of V-Belts for different combinations of pulleys available on the machine and the speeds of work-table were changed by adjusting the knob at already marked positions. The other main components of experiment set up are as given below.

A. Fabrication of Nozzle

Convergent nozzle was selected as shown in figure 1(a) & figure 1(b) shows cut section of the same. By taking the same dimensions as per design of the nozzle was made from aluminum rod of 42 mm diameter. The nozzle was

manufactured by boring operation of 7 mm diameter and finally the inside is finished by using the tool having the shape exactly that of internal geometry of nozzle.

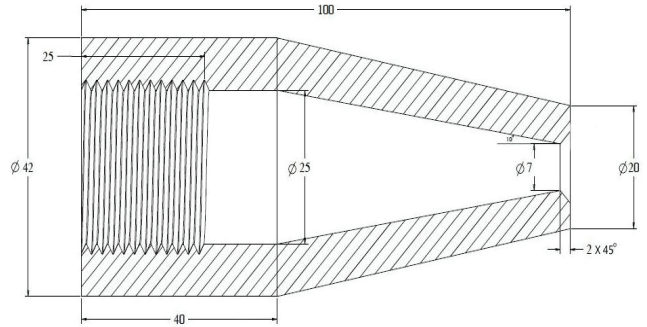

Fig. 1(a) Convergent nozzle

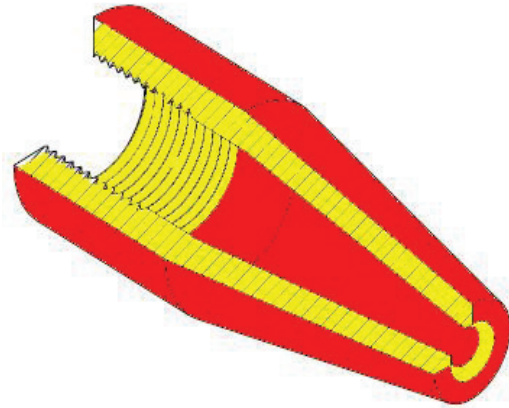

Fig. 1(b) Cut Section Convergent Nozzle

B. Centrifugal Pump

To pump the coolant flow to the required pressure 1.5 hp centrifugal pump was used. The fluid pressure is controlled with the help of a pressure regulating valve.

C. Pressure Gauge

Pressure is measured with the help of pressure gauge (0- 30kg/cm² range)

D. Coolant Tank

A sump tank of capacity 100 liters was used, from where pump sucks the coolant and after performing the cooling action it again gets collected in it after filtering the chips.

E. Protractor

Nozzle angle with the horizontal was changed using screw arrangement and the angle was measured on the protractor with different angles marked on it. Before starting the experiments the grinding wheel was balanced to avoid vibration if any and it was dressed using dressing tool.

F. Speed Set-Up

The speed of the wheel was changed by changing the position of V - belts on various pulley combinations available on the machine. The speeds of work – table were changed by adjusting the knob at already marked positions. The nozzle tip distance is varied with the help of screw arrangement. Control is provided on the machine for the in-feed of wheel –head and traverse table.

IV. EXPERIMENTATION

Three pieces of dimension 75x50 mm were cut from 10 mm thick mild steel flat with the help of power hacksaw. They were firstly rough ground on the surface grinder to reduce their thickness to 9.1 mm and then they were finally finished to the required thickness of 9 mm on surface grinder. On each work-piece three cuts were applied. The two cuts were of 50 microns each and one cut was made with coolant throw on work-piece. Convergent nozzle was selected, by taking the same dimensions as per drawing of the nozzle was made from aluminum rod. For pumping the coolant to the required pressure 1.5 hp centrifugal pump was used. The fluid pressure is controlled with the help of a pressure regulating valve and the pressure is measured with the help of pressure gauge. A sump tank of capacity 100 litres was used, from where pump sucks the coolant and after performing the cooling action it again gets collected in it after filtering the chips.

Eighteen pieces were made on wire cut Machine. Nine pieces were made to check the dimensional accuracy and nine pieces were made on polishing machine with different grade of emery paper to check the Micro hardness of Specimens sample available in EMM laboratory of PTU Giani Zail Singh Campus Bathinda.

The three values of nozzle angle were selected are given in Table I. The schematic of nozzle arrangement is shown in Figure 2 in which the provision to change nozzle angle was made. The speed of the work piece table is varied by adjusting the knob of the hydraulic system to the already marked positions the various speeds are given in Table II. The values of the input process parameters are changed as per design of experiment for the Grinding.

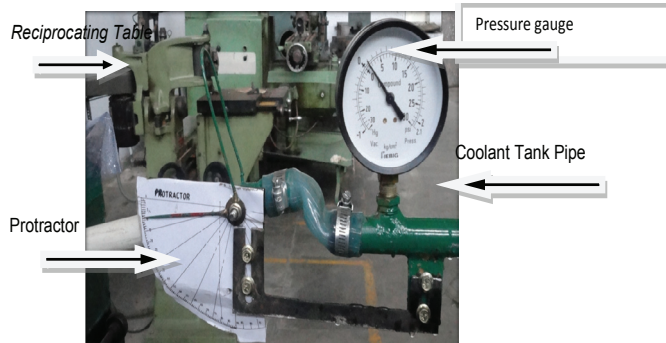

Fig. 2 Schematic of Experimental Setup

V. MEASUREMENT OF SURFACE ROUGHNESS

The Surface Roughness was taken with the perthometer (Make: Time; Model: TR-100) Pick up: Pizeoelectric available in the mechanical measurements and metrology laboratory. The results observed for the surface roughness (Ra value) are shown in the Tables III for the nine trials as per experiment design with five replications of surface roughness value. The experimental results for surface roughness (Ra) were analyzed graphically for all four variables and mean values of main effect as shown as bar diagrams. Nozzle angle with its lowest value (6°), inlet pressure 27kg/cm², wheel speed 2800 RPM and work piece speed 1.5 meter/minute is least significant in affecting the surface finish. The change in surface roughness values with the change in selected parameter is shown Figure 3 to Figure 6. It can be seen from these figures all the parameters have an effect on the surface roughness value of grinded mild steel specimens.

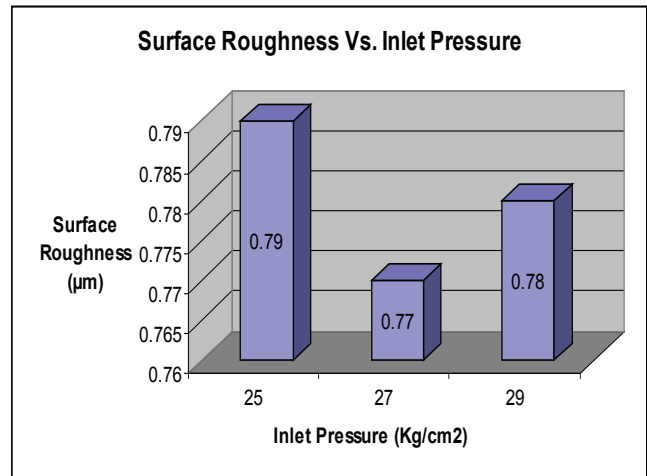

Fig. 3 Main effect of inlet pressure on surface roughness

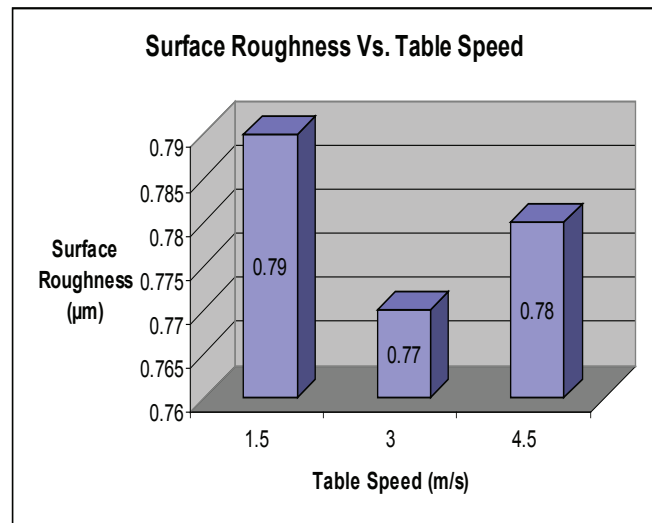

Fig. 4 Main effect of table speed on surface roughness

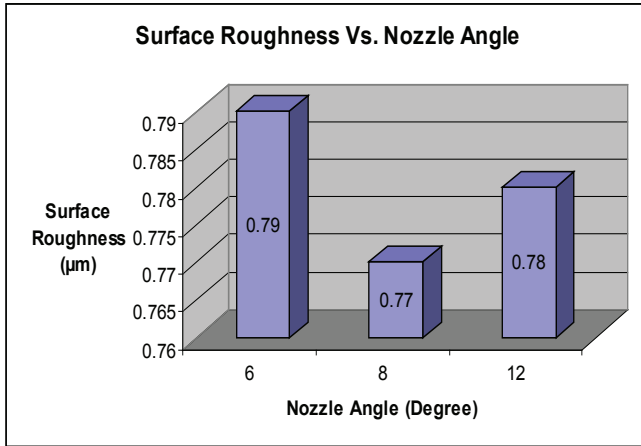

Fig. 5 Main effect of nozzle angle on surface roughness

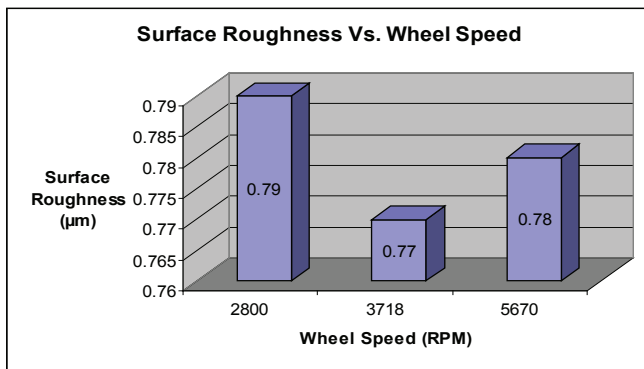

Fig. 6 Main effect of wheel speed on surface roughness

VI. CONCLUSION

The following are the conclusions drawn from the discussions:

1. The investigation of the surface grinding process parameters shows that all the selected parameters i.e. inlet pressure of coolant, grinding wheel speed, and table speed and nozzle angle have affect on the quality of the finished mild steel work-piece.

2. The value of surface roughness of grinded mild steel work-piece varies from 0.77 µm to 0.79µm. The value of Minimum surface roughness value 0.77 µm is obtained as per set of parameters given below:

Inlet coolant pressure 27 kg/cm², Wheel speed 2800 RPM, Work piece speed 1.5 m/min and Nozzle angle 6°.

REFERENCES

1. W. Brian Rowe, *Principles of Modern Grinding Technology*, William Andrew Applied Science Publishers, First Edition, pp. 1-9, 35-58, 2009.
2. T. Tawakoli, A. Rasifard and M. Rabiey, High-efficiency internal cylindrical grinding with a new kinematic, *International Journal of Machine Tools and Manufacture*, Volume 47, Issue 5, pp. 729-733, April 2007.
3. J.F.G. Oliveira, E.J. Silva, C. Guo and F. Hashimoto, Industrial challenges in grinding, *CIRP Annals - Manufacturing Technology*, Volume 58, Issue 2, pp. 663-680, 2009.
4. Murat Kiyak and Orhan Cakir, Study of surface quality in dry and wet external cylindrical grinding, *International Journal of Computational Materials Science and Surface Engineering*, Volume 3, Issue 1, pp. 12-23, 2010.
5. O. Cakir, A. Yardimeden, T. Ozben and E. Kilickap, Selection of cutting fluids in machining processes, *Journal of Achievements in Materials and Manufacturing Engineering*, Volume 25, issue 2, pp. 99-102, December 2007.
6. J.A. Webster, C. Cui, R.B. Mindek Jr. and Dr. R. Lindsay, Grinding fluid application system design, *CIRP Annals - Manufacturing Technology*, Volume 44, Issue 1, pp. 333-338, 1995.
7. V.A. Baines-Jones, M.N. Morgan, D.R. Allanson, A.D.L Batako, *Grinding fluid delivery system design-Nozzle Optimization*, European Research Council Grant No: GR/S82350/01.
8. H. Z. Choi, S. W. Lee, D. J. Kim, Optimization of cooling effect in the grinding with mist type coolant, *American Society for Precision Engineering Proceedings*, Crystal City, Virginia, November 2001.