

# Fatigue Analysis of Engine Blade Structure Considering Thermal Loads

Sabbir Hyder<sup>1</sup>, Serajee MD Toriqul Arman<sup>2</sup>, Montasir Adnan Adar<sup>3</sup> and Md Irfan Uddin Ahmed Mehedi<sup>4</sup>

<sup>1,2&3</sup>Aircraft Design and Engineering, Nanjing University of Aeronautics and Astronautics, China

<sup>4</sup>Department of EEE, Shahjalal University of Science and Technology, Bangladesh

E-mail: mdadnan57017@gmail.com, starman@nuaa.edu.cn, montashirad@gmail.com, mehedicullen@gmail.com

(Received 31 August 2023; Revised 19 October 2023, Accepted 18 November 2023; Available online 25 November 2023)

**Abstract** - Engine turbine blades are subjected to cyclic thermal stress during engine start-up, shutdown and various operating conditions. These thermal loads may generate temperature gradients and tensions inside the blades, which may cause structural fatigue damage and failure, and in severe cases may directly lead to flight accidents. In order to ensure the integrity and reliability of the engine blade structure, the fatigue analysis of the engine blade structure considering thermal stress is of great significance for the safety of aircraft. In this paper, the fatigue life of the engine blade structure is simulated and analysed considering the thermal load. Firstly, the research background and current research status are briefly introduced, and then the relevant theories for fatigue analysis of blade structures are elaborated. Then, a three-dimensional engine blade structure model is built in CATIA software, and it is imported into ANSYS software for thermal stress analysis. On this basis, the thermal fatigue calculation of the blade structure is further done, and the fatigue life of the structure is obtained when the thermal load is considered.

**Keywords:** Fatigue Analysis, Blade Structure, Thermal Load, Finite Element Method

## I. INTRODUCTION

### A. Background Study

Analysing a component or system's structural integrity after repeated loading or cyclic stresses is a procedure known as fatigue analysis. In addition to estimating the component or system's lifespan under cyclic loading conditions, the research also assesses the risk of fatigue failure. Loading analysis identifies the type of load conditions, magnitude, component, and frequency of the cyclic loading. Material Properties considered the material type, strength, and fatigue characteristics, such as the fatigue limit, fatigue strength, and endurance limit. By using computer simulation software or analytical techniques Stress analysis is determined. The estimated fatigue life of a component or system is possible using the stress study's findings and the material's parameters. Assessment of fatigue is to evaluate the risk of failure due to fatigue by contrasting the predicted fatigue life and fatigue failure if the estimated fatigue life is shorter than the anticipated life. More than 75% of turbine blade failures have been caused due to fatigue alone [1-2].

Overall, fatigue analysis is crucial for guaranteeing the secure and dependable operation of structures and components subjected to cyclic loads. Thermal fatigues on

turbine blades cause cracks to spread causing blade structure failure. It shortens the turbine blades' lifecycle and decreases the engine's efficiency. It shortens the turbine blades' lifespan and reduces the engine's operational efficiency. A gas turbine or steam turbine generates energy from the combustor's high-temperature, high-pressure gas. Recent developments in hydrogen fuel-based aircraft gas turbine propulsion introduce new chapters for turbine blade design. The flame temperature often exceeds the thermal limit of gas turbine engine blades, primarily when hydrogen fuel is used instead of the currently utilized aviation-grade kerosene fuel.

A multilayer ceramic coating of the turbine blade and the ablative cooling method is presented to satisfy the new design requirement for hydrogen-based gas turbine blades. The temperature distribution and thermal-stress field in various service phases of a turbine blade with thermal barrier coatings are analysed using the conjugate heat transfer analysis and the decoupled thermal stress calculation technique. "Thermal barrier coatings (TBCs) as a kind of temperature resistance material have been widely applied in super high temperature components in aircraft engines" [3-4]. It demonstrates that the temperature distribution on the blade surface is not uniform, which substantially impacts the stress field. The greatest temperature is 1030 °C at the leading edge. Peak compressive stress at the leading edge is 3.5 GPa. "It is possible to forecast that during the steady stage, the risk regions will probably be on the suction side, while the leading edge may be more susceptible to failure as the temperature drops" [5].

### B. Literature Review

In analysing the structural integrity and lifetime of engine components, particularly those that are susceptible to heat stresses, fatigue analysis is crucial. This study of the literature provides an overview of work done on thermal loads in the context of fatigue analysis of engine blade constructions. The paper provides useful information for researchers interested in enhancing the fatigue life prediction of engine blades under thermal loading circumstances by summarizing major discoveries, approaches, and difficulties encountered in the area. Proposed a new energy critical plane damage parameter for

the fatigue life prediction of gas-turbine blades [6]. To assure its dependability and safety, the design of a fatigue resistant 3D engine blade construction incorporates a number of factors.

The blade's fatigue life is greatly influenced by the material choice. Composites and titanium alloys are materials that are fatigue resistant. The blade's form and design must be improved to lower stress concentrations, reduce weight, and boost strength. Some design elements that can increase the blade's fatigue life include the use of fillets, rounding of corners, and optimizing the cross-sectional area. However, many operating practices and analyses have shown that the failures of hot channel components, such as turbine blades, are related to the uneven temperature field and local high thermal stress during service [7-9].

An explanation of the effects of fatigue on structural integrity. Stress-life (S-N) and strain-life (-N) approaches are prediction methods for fatigue life. The weight functions are determined as a parameter of the S-N curve and the fatigue stress limit of the material [10-11]. Material properties, loading conditions, and environmental factors all affect fatigue behaviour. Thermal stress may be caused by combustion, heat transfer, and aerodynamic factors while building engine blades. Thermal cycling, thermal expansion, and temperature gradients' effects on fatigue behaviour. The influence of the rim seal flow and the guide vane passing wake on the aerodynamic and heat transfer in a single-stage axial gas turbine was fully introduced [12]. The impact of thermal barrier coatings on how thermal stress is distributed. Engine blade constructions are tested experimentally for fatigue under heat stresses. In this procedure, instruments, and monitoring methods for collecting temperature fluctuations and structural reactions are utilized.

Standards and procedures for fatigue testing are unique to thermal loading scenarios. Used the FEM method to analyse the elastic-plastic and creep behaviour of a high-pressure turbine blade, and noted that prior to mechanical analysis, more accurate results can be obtained through thermal analysis [13]. Methods for modelling thermal stresses include finite element analysis (FEA) and computational fluid dynamics (CFD). Constitutive equations and material models for precisely describing thermal mechanical phenomena. correlation with experimental data for the purpose of numerical model validation and verification. creation of engine blade structural thermal fatigue life prediction models. Analysed the effects of the damage occurring in the second-stage blade of a gas-turbine engine, thereby reducing its fatigue life [14]. Incorporating the impacts of heat load into the current fatigue analysis techniques. approaches for taking into consideration the unpredictability of heat loads and material characteristics.

### *C. Major Work and Structure*

This work focuses on the Numerous Finite Elements Analysis (FEA) solution techniques and the coupling of

various Numerical solvers techniques, which are used to assess the massive thermal loads of engine blades and fatigue analysis method. This paper's major work and structure are as follows:

The first chapter is an introduction that explains the context and relevance of the topic selection, which is divided into fatigue analysis, design, measurement, and engine blades thermal loads measuring study. Construct a solid theoretical and practical foundation.

The principle is the second chapter, and it briefly explains A Synopsis of Related Theories and essential principles and Applications.

The measuring experiment was done in the third chapter. To begin, design simulation tests determine the relative locations and included angles of the blade loads. The practicality of the Finite Elements Analysis (FEA) solution techniques approach was then confirmed by measurement tests theory, simulation, and experiment to verify the method's effectiveness.

The fourth chapter compares prior experimental data pictures, demonstrating that Finite Elements Analysis (FEA) method's measurement results are accurate and consistent.

## **II. A SYNOPSIS OF RELATED THEORIES**

### *A. Fatigue Analysis Symptom-based on the Engine Blade Method*

Primarily engine blades are known as the Fatigue Analysis Symptom-based on Engine Blade Method (FASEM). The FASEM conduct measures the number of fatigue damage symbols, such as cracks or pitting, that manifest on engine blades and expanse over a particular period. The FASEM approach entails keeping a lid on and monitoring engine blades for evidence of fatigue damage over a particular period. To attempt to locate any physical signs of damage due to fatigue on the blades, the test process frequently uses a non-destructive technique for testing, such as visual examination, eddy current examination, or ultrasonic inspection. After the inspection information is finally gathered, it is statistically evaluated to ascertain the quantity and seriousness of the indications of fatigue damage that are visible on the engine blades. The turbine blades are often the limiting component and were considered the critical components of gas turbine engines in which failures occur frequently [15].

A model for forecasting the blades' remaining fatigue life is developed utilizing this information. Because it takes into consideration the individual operating circumstances and stresses that the components face over their service life, the FASEM approach is particularly helpful for estimating the remaining fatigue life of gas turbine engine components. The FASEM approach can assist maintenance teams in planning and scheduling maintenance activities, decreasing

the chance of unplanned downtime and lowering maintenance costs. It does this by properly forecasting the remaining fatigue life of engine blades. The assumption of this approach is based on the previous understanding that the mode shapes remain unchanged in the case of lightly damped turbomachinery blades [16]. The principal failure mode for the blade under the challenging alternating loads encountered during operation is fatigue damage. Numerous catastrophic mishaps to the engine and potentially the entire aircraft would result from the breakdown of the blade. Therefore, an appropriate fatigue damage model must be built to calculate the blade's remaining life. Of all structural fatigue calculation methods, Palmgren- Miner [17]. linear cumulative damage model is widely used and could be expressed as

$$\begin{aligned} D &= \sum_{i=1}^n n_i \\ N_i &= \sum_{i=1}^n r_i \end{aligned} \quad (1)$$

Where  $D$  is the damage variable,  $N_i$  is the component failure cycles under the same stress amplitude, and  $n_i$  is the cycles under the stress amplitude of  $i$ . The damage produced every cycle is assumed to be independent of the load factors in this model. However, fatigue damage is a deteriorating process under cyclic loading, and the damage variable is closely related to external loads (stress or strain) [18]. As a result, many real-world situations do not support the Miner linear cumulative damage model (LDM) inferences. Ti (Titanium) emphasized that the linear cumulative damage technique is inapplicable for estimating roulette components' lifespan and aero-engine blades' lifespan. The linear damage technique would often overestimate life expectancy by several times. Therefore, the non-linear continuum damage theory was raised. RABOTNOV, *et al.*, [19-20], proposed damage factors concepts and began a study on continuum damage mechanics. Marco and Starkey first proposed a non-linear and load-related damage law [21].

$$D = \sum_{i=1}^n r_i x_i \quad (2)$$

Where  $x_i$  is a variable associated with load number  $i$ . This model may be computed with various load orders and has good agreement with the findings of experiments. While  $x_i$  needs to be recalculated following the various loads and loading circumstances. Eq. (2) is therefore limited for estimations of cumulative harm.

### B. Finite Element Analysis Based on Engine Blade

A numerical technique called finite element analysis (FEA) is used to examine how complex systems and structures behave under various situations. In engineering and other industries, it is frequently used to develop and optimize products, forecast performance, and determine safety. A complicated structure is broken down into smaller, simpler components so that they may be examined using mathematical equations. This is the fundamental notion underlying FEA. To provide a rough answer for the

behaviour of the entire structure, these equations are then numerically solved. The connections between the components, known as nodes, enable the transmission of forces and displacements between adjacent elements. A computer technique called finite element analysis is used to examine how buildings respond to different loading scenarios. The performance and strength of components, such as engine blades, are frequently studied in engineering fields. FEA may be used to examine an engine blade, as seen in the following overview. The first step is to use CAD software to produce a 3D model of the engine blade shape. The model must faithfully depict the blade's characteristics, size, and form.

To build a mesh for FEA, the 3D model is broken up into smaller, finite-sized parts. By linking nodes and components, the mesh formation process discretises the blade shape. The complexity of the investigation and the required accuracy determine the element type and mesh density.

A thermomechanical finite element analysis model for examining the wear and tear on engine pistons. An FEA piston stress and fatigue model is developed. The piston's loading characteristics during accurate operation are simulated. Using the developed FEA model, the piston's stress and fatigue assessments were performed. The outcomes were contrasted with those previously documented in the literature. The piston's real operating circumstances may be more closely modelled using the existing model. It resolves the design direction and optimization of a piston in a powerplant [22].

An FEA was carried out with the FSI method the result was verified with the actual scenario. Theoretical support will be provided for the problem's following materials and structure optimization of the exhaust manifold, which will serve as a crucial reference for the prevention of thermal fatigue damage and the forecast and management of life under high temperatures and thermal shock [23].

Utilizing the CFD approach, the change in aerodynamic performance and the flow field exhibit distinct flow characteristics that are utilized as input for structural calculations. Running a structural vibration simulation of a whole-bladed disk using component mode synthesis and wave base sub-structuring incorporates this into the study. Under thermomechanical stress, a single blade's fracture opening, and closure are influenced by the variation in vibration amplitudes. These phenomena, such as thermal expansion, are investigated using the extended FEA approach. Two genuine turbine blades are used to compare the properties of a new and worn turbine blade [24].

### C. Considering Blade Thermal Load

The thermal solid coupling method may be used using static structural and steady-state thermal analysis solvers. In this method, the coupling's complexity is reduced and a more accurate result for the prediction of the fatigue life may be

obtained. The goal of this study is to investigate the fatigue life of a gas turbine blade under conditions of severe thermal stress. With cutting-edge CAE technology, we can tackle the issue from all sides. To do a chemical analysis on a turbine rotor blade, a sample was taken from the precise problematic blade region. This sample was then utilized to carry out observations on the chemical composition and material balance of various components. The material compositions of a turbine blade surface are made from Titanium (Ti). The Chemical composition of the Titanium blade Standard Specification is 3.5-4.5%.

The particular application and operating circumstances must be considered while analysing titanium blade thermal loads. Due to its superior strength-to-weight ratio and durability to high temperatures, titanium is a common material option for a variety of components, including turbine blades in the aerospace and power generation sectors. Blade thermal loads are the tensions and fractures brought on by temperature fluctuations in a turbine's operating environment. The added mass was considered as a region of fluid attached to the moving boundary which adds to the total inertia force of the body [25].

Compared to other metals, titanium has a relatively low thermal conductivity, which causes it to retain heat and suffer substantial temperature gradients throughout its thickness. The thermal expansion coefficient of titanium is relatively high. When titanium is heated, it expands; when it is cooled, it contracts. Particularly at interfaces or regions with temperature differences, these expansion and contraction motions have the potential to cause stresses in the blade. Titanium blades are susceptible to thermal stress from many heating and cooling cycles.

When there are large temperature differences throughout the blade, which result in localized expansion and contraction, this can happen. In a compressible flow case, the added mass term is proportional to the length of the time interval, while for an incompressible flow case, it can yield unstable computations and is highly dependent on the mass density ratios of the fluid to solid domains [26]. This may eventually cause fracture initiation and propagation, endangering the integrity of the blade. Titanium dissipates heat more slowly than other metals because it has a poorer thermal conductivity than those other metals. Extensive consideration of this effect in the context of a fluid-structure coupled analysis was given in Liu and O'Farrell [27].

Localized hot spots may develop on the blade as a result of this, particularly in regions exposed to high temperature gases or thermal gradients. Turbine blades are comprised of titanium alloys that have been specially designed to withstand extreme pressure and thermal cycling. Aluminium, vanadium, and molybdenum are frequently added to these alloys to improve their high-temperature strength and creep resistance. To make sure the blade can handle the projected heat stresses, careful material selection is essential.

The method is unconditionally stable and involves the solution of structural stiffness for every timestep. Finite element analysis (FEA), a computational technique, is frequently used to simulate and assess the thermal stresses on blades [28]. The turbine blades are often the limiting component and were considered the critical components of gas turbine engines in which failures occur frequently [29].

These models take into account things like the stress distribution within the blade as well as the temperature distribution and heat transmission. To reduce excessive thermal loads, FEA can assist in optimizing the blade design and cooling system. Thermal loads on engine blades describe how much heat is produced when an engine is running. The performance and longevity of the engine may be impacted by the considerable heat stresses placed on the engine blades. Here are some crucial factors to take into account while analysing engine blade thermal loads. Highly reliable control sensors need to be used to avoid such incidents [30].

### III. ANALYSIS OF BLADE STRUCTURE

#### *A. Design of Blade 2D Geometry Using CATIA*

##### *1. Engine Blade Computer Aided Design Parameters*

The significance of blade design is analysed by Catia. Aviation, wind, and water turbine blades have all been designed and developed using the computer-aided design program CATIA. We may use the software's numerous capabilities to examine the importance of blade design. To forecast how well an aircraft's aero blades would operate, aerodynamic models frequently employ airfoil data tables. The simulation program can compute the lift, drag, and other aerodynamic forces operating on the aero blade by using the airfoil data table and other factors, which allows us to generate a CATIA CAD design.

##### *2. Catia Point Cloud Design for Blade Geometry*

The design and optimization of the blades used in aircraft engines fall within the difficult and specialized field of aeronautical engineering. The basic goal of airfoil blade design is to provide effective, long-lasting, and secure blades. Aerodynamics is one of the primary factors in the design of airfoil blades. To optimize lift and decrease drag, the blade's form and profile must be meticulously constructed. It must also be sturdy and quiet in order to achieve these goals. In order to assess and improve blade performance, computational fluid dynamics (CFD) simulations are frequently used in the design process.

To construct and analyse complicated forms, surfaces, and structures, the design offers a wide range of tools and functions. The information below is derived from (Fig. 1) and is used to construct an airfoil blade structure in CATIA.

### 3. Blade Geometry Parameters

In the design of airfoils, the shapes of the upper and lower surfaces are referred to as  $Y_{cc}$  and  $Y_{cv}$ , respectively. “Y-coordinate of the camber line on the concave side” is abbreviated as “ $Y_{cc}$ ,” while “Y-coordinate of the camber line on the convex side” is abbreviated as “ $Y_{cv}$ .” The camber line, which represents the airfoil’s average curvature, is a line drawn halfway between the upper and lower surfaces. The distance from the chord line to the camber line on the concave (or upper) side of the airfoil is designated by the letters  $Y_{cc}$ , while the space on the convex (or lower) side is designated by the letters  $Y_{cv}$  (Fig. 2).

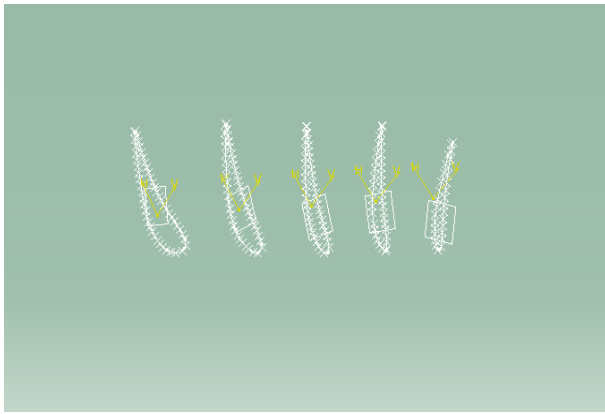

Fig. 1 Point cloud method for airfoil shape

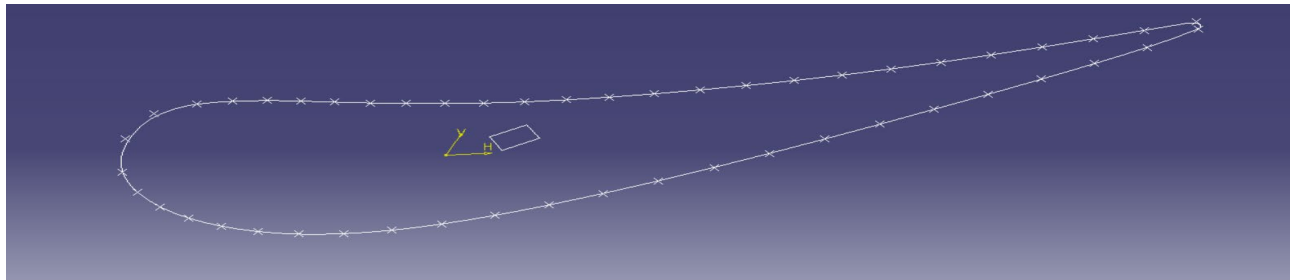

Fig. 2 Blade structure’s upper part is concave ( $Y_{cc}$ ) and the lower part is convex ( $Y_{cv}$ )

The values of  $Y_{cc}$  and  $Y_{cv}$  Blade a crucial role in the design of airfoils because they affect the properties of lift and drag. An upper surface that is more curved often has a more significant value of  $Y_{cc}$ , which can increase lift but also increase drag. Similar to this, a higher value of  $Y_{cv}$  denotes a lower surface that is more curved, which can similarly increase lift but also increase drag. The  $Y_{cc}$  and  $Y_{cv}$  values of an airfoil may be measured and analysed using various tools provided by CATIA, including the ability to plot the camber line and determine the coordinates of specific spots on the airfoil surface. The airfoil shape may be improved using these measurements for maximum performance in a particular application.

### B. Design of Blade 3D Geometry Using Catia

#### 1. Principles Blade 3d Geometry Design

A form of the airfoil that has numerous sections, each having its own distinct shape and design specifications, is known as a multi-section solid airfoil. Designers may develop and evaluate multisection solid airfoils using a variety of tools and capabilities provided by CATIA, including (Fig. 3).

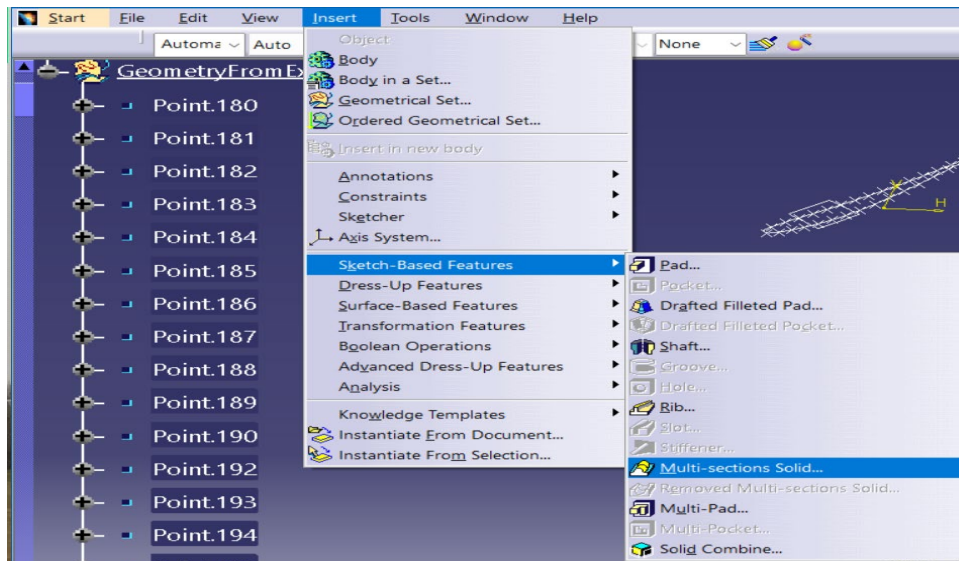

Fig. 3 Multi-Section Solid

This process allows the construction of the structure and Section of all the solids. In the process, all of the Airfoil data is imported and analysed. We will find a sketch of the blade structure. Using the spline tool is the process for producing a multi-section solid airfoil.

For each segment of the airfoil, a series of curves was made from airfoil data, and these curves must then be blended together smoothly using the spline tool. by utilizing the analytical tools in CATIA to assess a multisection solid airfoil's performance property, such as lift, drag, and stability. Data from wind tunnel simulations or

computational fluid dynamics (CFD) analyses also can be used for this.

### 2. Shape of the Upper Part of the Blade Geometry

We obtain the blade form after entering all the data (Fig. 4). We can see the sectors points, the smooth parameters, and the angular adjustment in this design. The airfoil is given thickness to give it a more realistic form once the 3D model has been produced. The thick tool in CATIA may be used to accomplish this, producing a solid airfoil with a predetermined thickness.

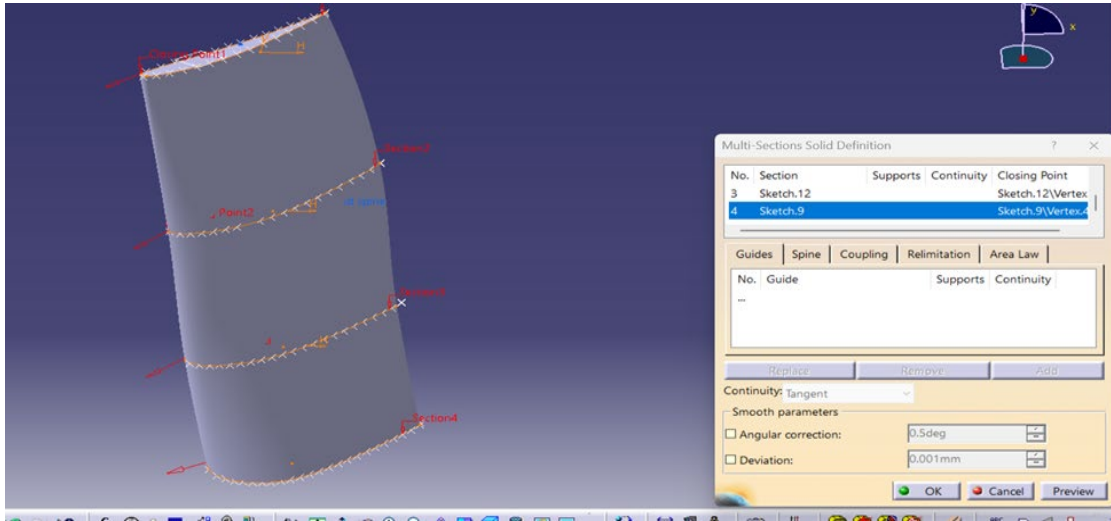

Fig. 4 Shape of the upper part of the blade

The airfoil's shape should then be improved by modifying variables like camber, thickness, and curvature to maximize lift, drag, and other performance traits. Lofting, splining, and optimization tools, among other CATIA tools and capabilities, can be used for this. Once the airfoil blade shape has been decided upon, it is crucial to test the airfoil's performance using computational fluid dynamics (CFD) analysis or data from wind tunnel simulations. A variety of analytic tools are available in CATIA that may be used to assess the lift, drag, and other performance traits of the airfoil upper blade.

### 3. Shape of the Lower Part of the Blade

Gas turbine engine blades are frequently fastened to the rotor disk using fir tree roots. The blade's root is shaped like a fir tree and has grooves carved into it that correspond to the contours of the rotor disk. The fir tree root, a key component of airfoil design, aids in fastening the blade to the rotor disk and ensuring that it stays in place throughout the operation. A solid fit between the blade and the rotor disk is provided by the root, which is often constructed of a strong, lightweight material like titanium (Fig. 5).

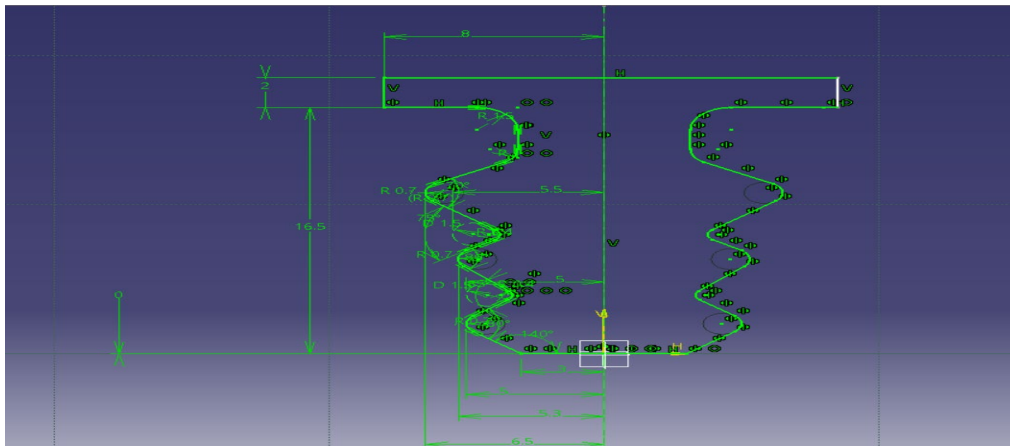

Fig. 5 Fir Tree Root



Designers may generate the fir tree root of an airfoil in CATIA using various tools and capabilities.

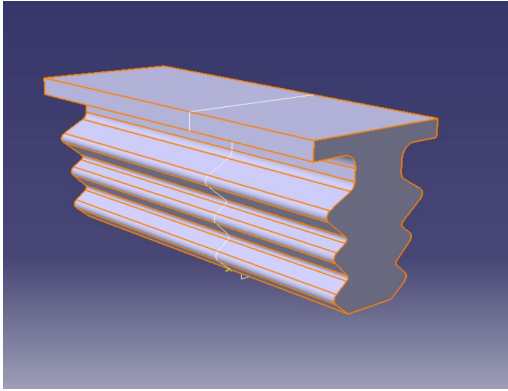

Fig. 6 Fir Tree Root 3D Design

Typically entails using solid modelling, extrusion, and sketching tools in CATIA to create a 3D model of the root shape (Fig. 6). To guarantee that the final model satisfies the performance requirements of the particular application, the model may then be improved by utilizing a variety of CATIA capabilities, such as lofting, splining, and optimization tools. Using a mix of sketching, extrusion, cut features, and optimization tools to perfect the root's shape for optimum performance is necessary to create a 3D model of a fir tree root in CATIA.

#### 4. Combined Blade Geometry

The CATIA assembly tools can be used for this. To unite the top and lower fir tree root models into a single 3D model, by using CATIA's Boolean operation tool. We can combine two or more 3D models with this tool to create a single model. Once the models have been combined, the combined model should be further refined to ensure that it satisfies the application's performance requirements. Lofting, splining, and optimization tools are just a few of the several CATIA capabilities and tools that may be used to do this. It's critical to review the design for any flaws or problems that could affect its performance before it is finalized. The analytical tools in CATIA, such as the finite element analysis (FEA) tool, may be used to do this.

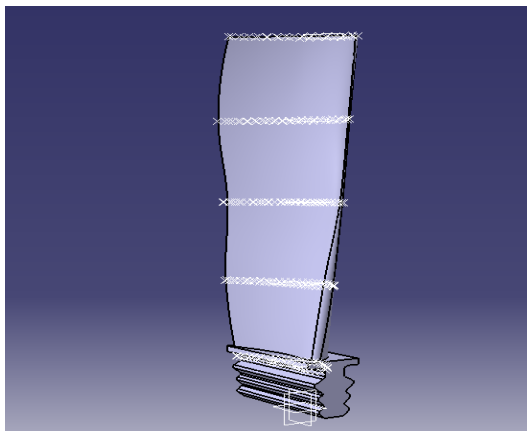

Fig. 7 Combined Blade Shape

We may produce an airfoil blade with a smooth link between the blade and the rotor disk by fusing the top and lower fir tree root models into a single 3D model (Fig. 7). By ensuring that the blade can endure the strains of operation in a turbine engine, this can assist to increase the blade's performance and longevity. Start by utilizing the procedures described in the preceding response to make separate 3D models of the top and lower fir tree roots. Once both models are finished, align them to make sure they are positioned correctly in relation to one another.

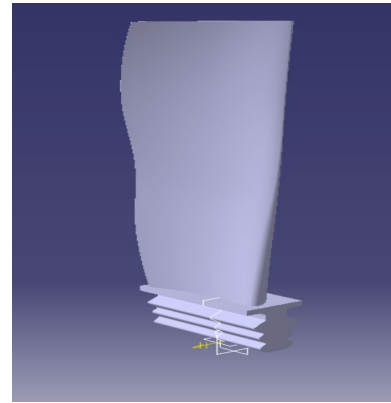

Fig. 8 The 3D shape of the Combined Blade Model

Overall, a 3D model of a combined blade detail in CATIA (Fig. 8) was created with a mix of technical expertise, attention to detail, and software knowledge. However, it is possible to produce extremely accurate and detailed models that satisfy the requirements of even the most complex aerospace applications with the proper methodology and tools.

## IV. SIMULATION AND STRUCTURE CONSIDERING THERMAL LOADS

### A. Ansys Software Data Entry

ANSYS software then conducts the thermal load consideration in the engine blade. The ANSYS program is a potent simulation tool used in many different sectors for engineering design and analysis. The process of entering input parameters or data necessary to run simulations and analyze outcomes is known as data entry in ANSYS software. Here are a few essential steps for entering data into the ANSYS software.

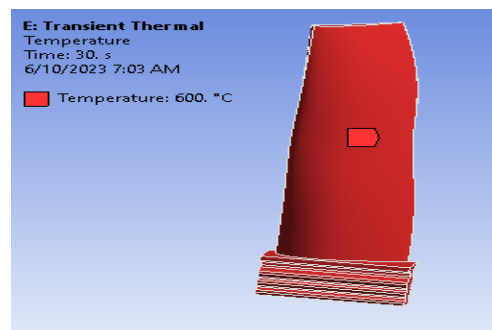

Fig. 9 Ansys Blade Temperature in Transient Thermal

The term “blade temperature” (600°C) in transient thermal analysis describes the temperature distribution and variation within a blade or any other object over time. The heat conduction equation is frequently used in transient thermal analysis to describe in (Fig. 9) the heat flow within the blade. It takes into consideration the effects of heating or

cooling brought on by numerous elements, including radiation, conduction, and convection. Describe the blade’s shape, composition, and starting circumstances. Its thermal conductivity, heat capacity, and beginning temperature distribution are all included.

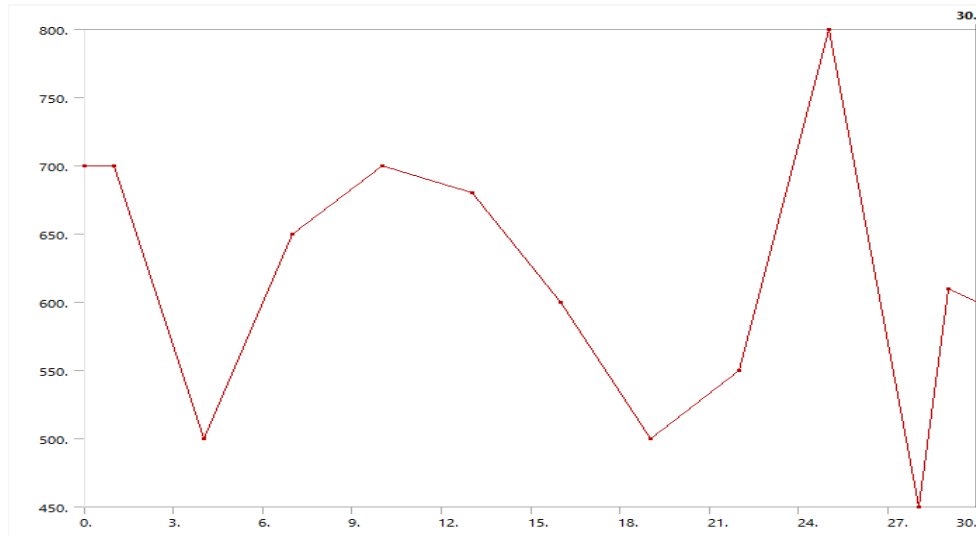

Fig. 10 Ansys Blade Temperature in Transient Thermal

The temperature boundary conditions for the analysis from (Fig. 10) we are doing must be specified when entering temperature data in the ANSYS program. Use ANSYS Mechanical’s temperature boundary conditions to describe the temperature value if the entire item is kept at a constant temperature. Use ANSYS Mechanical’s temperature boundary conditions to indicate the temperature gradient if the object’s temperature changes across it. Use the temperature boundary conditions provided by ANSYS Mechanical to indicate the temperature variance if the temperature changes over time.

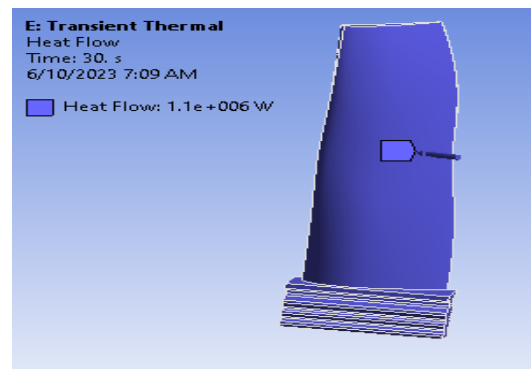

Fig. 11 Ansys Heat Flow



Fig. 12 Temperature of thermal analysis



Heat flux, a crucial factor in thermal analysis (Fig. 11) utilizing the ANSYS program, is the rate of heat transfer per unit area. Use ANSYS Mechanical's boundary condition settings to provide the heat flux value if the rate of heat transfer over a surface is constant. Use ANSYS Mechanical's boundary condition parameters to describe the heat flux distribution if the rate of heat transfer varies over a surface. Use the boundary condition settings in ANSYS Mechanical to indicate the heat flux fluctuation if the rate of heat transfer fluctuates over time. A meshing size of 2.0 mm was chosen, which is sufficient for this problem. (Fig. 12) The Temperature of the thermal analysis Graph flow has Fluctuated.

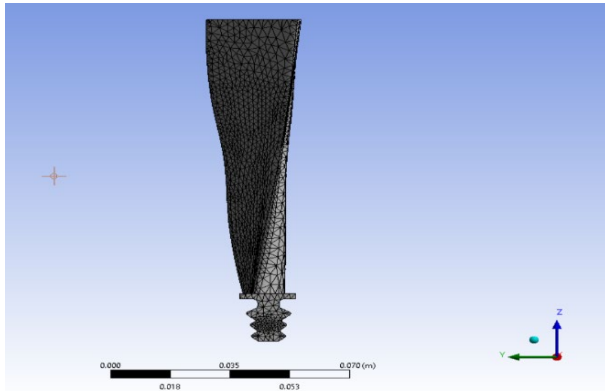

Fig. 13 ANSYS Mesh Analysis

ANSYS Finite Element Analysis (FEA) require the use of this mesh analysis (Fig. 13) a, b, and c Mesh simplifies complex geometry, basic parts, and mesh analysis is a critical step in this process. Creating a mesh or breaking down a complicated geometry into minor, basic parts is a vital step in the Finite Element Analysis (FEA) procedure. The analysis being done determines the kind of elements that are used for meshing.

Different element types, including solid, shell, linear, and quadratic, are available in ANSYS software. The geometry's size and shape, as well as the kind of analysis being done, are used to decide the element size. The ANSYS program offers several ways to adjust the element size, including curvature-based element sizing, local element sizing, and global element sizing. An essential FEA stage that influences the precision of the outcomes is ANSYS Mesh Analysis. To design, improve, and evaluate the mesh and provide precise and trustworthy results, ANSYS software offers a variety of capabilities.

*B. ANSYS Software Material Selection*

Titanium is one of the preset materials that are included in the material library offered by ANSYS software. The steps to choosing titanium as the material in ANSYS software are as follows.

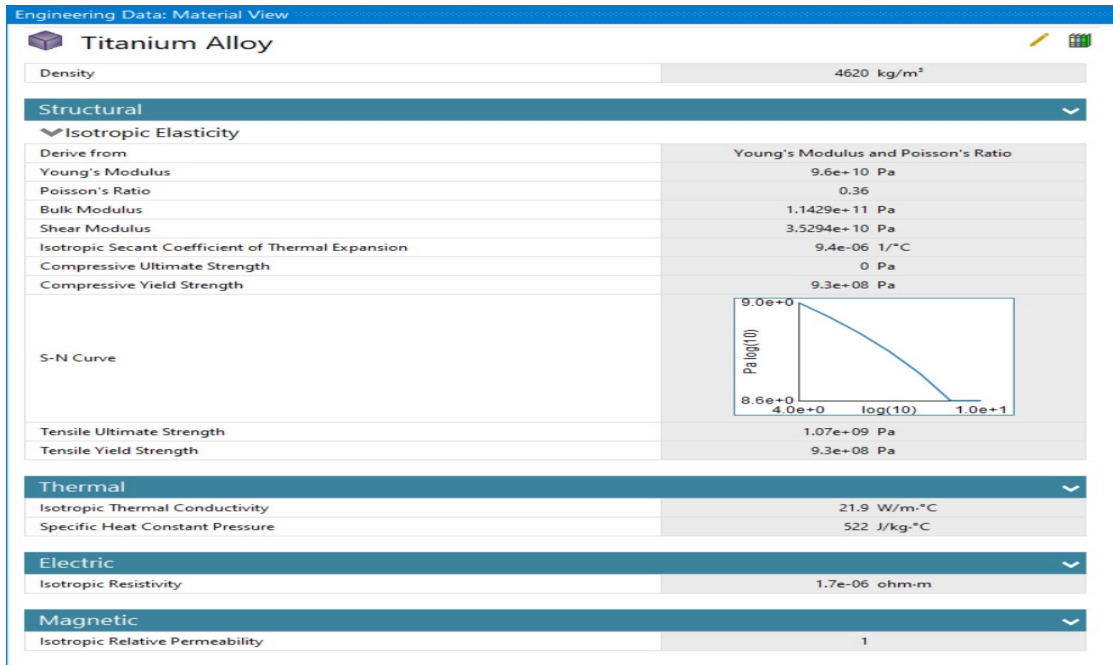

Fig. 14 Titanium Material Properties

In ANSYS software, selecting Titanium as the material entails opening the material library (Fig. 14), searching for titanium, and then designating the material to the body or interested part. The precision of the material characteristics ascribed to the item under study determines the findings achieved through simulation.

*C. Blade Thermal and Static Coupled Analysis Using ANSYS*

*1. Transient Thermal Analysis of Blade*

Various engineering systems, including the thermal examination of parts like blades, may be modeled and

analyzed using the robust simulation software package ANSYS. The study of temperature variations in a component over time, which can be crucial for understanding performance and dependability, is made possible through transient thermal analysis. The general procedures listed below can be used for transient thermal analysis of a blade in ANSYS. The transient thermal analysis simulates the heat transfer processes occurring within the turbine blade during transient events. It considers various heat transfer mechanisms, including conduction, convection, and radiation.

The ANSYS software employs sophisticated numerical algorithms to solve the transient heat conduction equation, providing a detailed understanding of the temperature distribution within the blade over time. The analysis predicts how the temperature of the turbine blade evolves during different phases of operation. For instance, during the start-up phase, the transient thermal analysis reveals the temperature rise within the blade as it is subjected to increasing heat input. This information is vital for assessing thermal stresses and potential thermal gradients that may affect the blade's structural integrity.

Furthermore, the transient thermal analysis considers the effects of convective heat transfer from the hot gas flow passing over the blade surface. This is accomplished by incorporating appropriate convective heat transfer coefficients obtained through experimental data or computational fluid dynamics (CFD) simulations. The convective heat transfer coefficients account for the complex fluid dynamics and temperature gradients occurring in the gas turbine engine.

The temperature distribution obtained from the transient thermal analysis provides insights into the regions of the turbine blade experiencing the highest thermal stresses. These regions, often near the leading and trailing edges, are prone to thermal fatigue due to cyclic temperature fluctuations during operation. By understanding the temperature distribution, engineers can identify critical areas that require additional thermal protection or cooling strategies to mitigate thermal stresses and enhance the blade's durability.

Additionally, the transient thermal analysis helps optimize the cooling system design of the turbine blade. By simulating the cooling air flow and heat transfer processes within the internal cooling channels, engineers can evaluate the effectiveness of different cooling configurations. This analysis enables the identification of optimal cooling strategies that maximize heat extraction and minimize temperature differentials, enhancing the blade's thermal performance.

The transient thermal analysis using ANSYS software plays a vital role in understanding the thermal behavior of a turbine blade during transient events. By simulating heat transfer processes, predicting temperature distributions, and

assessing thermal stresses, engineers can make informed design decisions to improve the blade's durability and performance. The analysis also aids in optimizing cooling strategies, enhancing heat transfer efficiency, and minimizing thermal differentials. Ultimately, the transient thermal analysis contributes to the overall efficiency, reliability, and longevity of gas turbine engines by ensuring the thermal integrity of turbine blades under varying operating conditions.

Moreover, the transient thermal analysis facilitates the evaluation of thermal response during sudden load changes or transient events. These events can lead to rapid temperature variations within the turbine blade, potentially causing thermal stress and fatigue. By simulating these transient scenarios, engineers can assess the blade's ability to withstand thermal shocks and identify any design vulnerabilities.

The transient thermal analysis in ANSYS provides a time-dependent temperature profile, allowing engineers to study the thermal response over different time intervals. This data can be used to validate the blade's thermal performance against design criteria and industry standards. Comparing the predicted temperature distribution with allowable limits ensures that the blade operates within safe thermal boundaries.

In addition to assessing the steady-state temperature distribution, the transient thermal analysis also enables the evaluation of thermal transients, such as the time it takes for the blade to reach a steady-state temperature during start-up or the cooling-down period after shutdown. These insights aid in understanding the dynamic thermal behavior of the blade and can inform operational procedures to mitigate thermal stress and potential damage.

The insights gained from the transient thermal analysis can guide design improvements for turbine blades. For instance, the analysis may reveal areas of the blade that experience excessive temperature gradients or hotspots. Engineers can then explore design modifications such as optimizing cooling hole placements or introducing thermal barrier coatings to reduce these thermal differentials.

Furthermore, the transient thermal analysis serves as a foundation for subsequent structural analyses, allowing engineers to perform coupled thermal and structural analyses for a comprehensive assessment of the blade's performance.

The temperature distribution obtained from the transient thermal analysis serves as input for the structural analysis, enabling the evaluation of thermal-induced stresses and deformations. This coupled analysis provides valuable insights into the blade's behavior under realistic operating conditions.

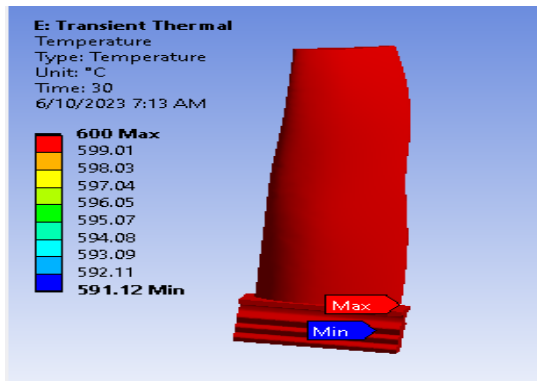

Fig. 15 3D Blade Temperature

The rate of heat transmission per unit area from a gas turbine blade surface to the surrounding gas flow is referred to as blade heat flux in Fig. 15. Allow us to clearly see the 3D blade temperature, location, and impact on the blades. We can observe the temperature flow along the route in Fig. 16. As a result of material deterioration, decreased efficiency, and eventually engine failure, it is a crucial factor in the design and operation of gas turbine engines. The gas flow velocity, temperature, pressure, and composition, as well as the blade geometry, surface roughness, and material qualities, all have an impact on the blade heat flux.

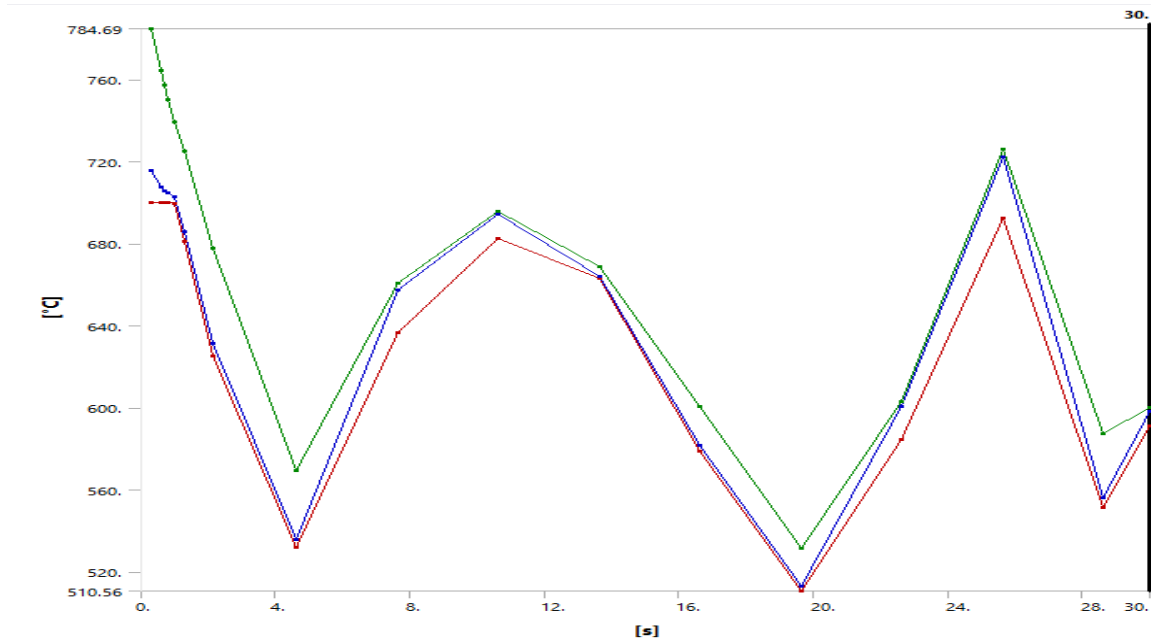

Fig. 16 3D Blade Temperature

Precise blade heat flux monitoring and forecasting are essential for safe and dependable gas turbine operation. In conclusion, the transient thermal analysis conducted using ANSYS software provides essential information about the temperature distribution and thermal response of a turbine blade during transient events. By simulating heat transfer processes, assessing temperature variations, and identifying critical regions prone to thermal fatigue, engineers can optimize the blade’s design, enhance cooling strategies, and ensure its structural integrity under varying operating conditions. The insights gained from the analysis contribute to the overall efficiency, reliability, and longevity of gas turbine engines by mitigating thermal-related failures and improving the blade’s thermal performance.

## 2. Blade Temperature

Understanding the behavior of the component and improving its design for optimum performance and reliability may be accomplished by doing a transient thermal study of a blade using ANSYS.

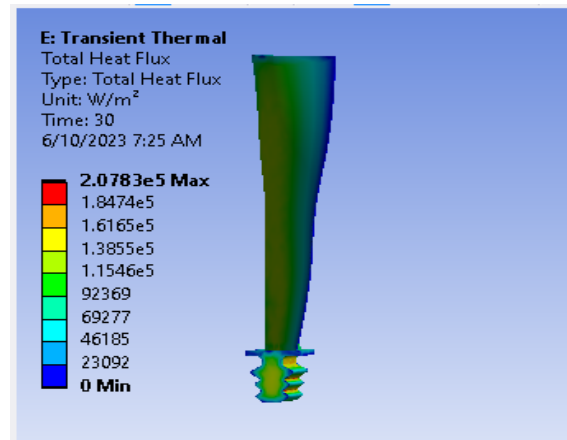

Fig. 17 Transient Thermal 3D Blade

The highest heat flow rate located on the lower part of the blade surface and upper region of firtree roto was observed. The research and characterization of heat transport events in a system that suffers time-dependent temperature variations are referred to as “transient thermal” processes.

Understanding how the blade reacts to temperature changes over time in Fig. 17. Blades require transient thermal analysis. The temperature of a turbine or engine's blades is referred to as the blade thermal temperature. Due to the combustion of fuel or other processes, the blades of a turbine or engine are exposed to high temperatures, which can induce thermal stress and eventually cause failure if the temperature exceeds its permitted limitations.

To avoid damage and maximize the efficiency of the turbine or engine, it is essential to measure and monitor the blade's thermal temperature. Blade temperature may be measured using a variety of tools, including thermocouples, pyrometers, and infrared cameras. These techniques are used to collect information on the temperature distribution across the blades, which may then be studied and utilized to improve the turbine or engine's construction and performance.

### 3. Blade Deformation

In ANSYS, the term "blade deformation" refers to the examination of how a blade, typically a turbine or compressor blade, behaves when subjected to loads or forces from the outside. The performance and efficiency of a turbine or compressor might be impacted by blade deformation, thus it's critical to assess the situation and take steps to reduce it as much as feasible. The general procedures for analyzing blade deformation in ANSYS are as follows.

In ANSYS, create a 3D model of the blade with all the necessary information, such as the blade's shape, the material's characteristics, and the boundary conditions. To achieve correct results, mesh the blade model using the proper mesh sizes and element types. Apply suitable boundary conditions, such as the loads and limitations the blade would face in real-world situations, to the blade model. Maximum total deformation of 0.08m was located on the upper part of the blade and lowest on the fir tree root.

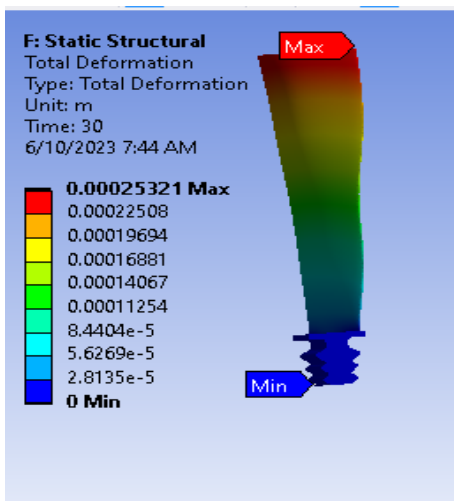

Fig. 18 3D Static Structural Analysis Total Deformation Result

Total deformation is the term used to describe the entire displacement and distortion that a structure experiences when it is subjected to loads or external pressures. It tells us how far if at all, the structure deviates from its initial position in response to the applied stresses. Knowing how to use the blade Expressed in terms of the size and direction of displacements at different sites or nodes in the structure, total deformation changes with time in Fig. 18.

### 4. Blade Static Structure

A finite element analysis program called ANSYS is used to model how structures would behave under different loads and circumstances. The blade's 3D geometry must first be created in ANSYS. The geometry tools that are already built-in may be used for this, or you can import a CAD model. Following the creation of the geometry, a mesh of small elements is produced to represent the properties and shape of the blade. The mesh should be sufficiently fine to capture the crucial blade geometry features without being computationally costly.

Defining the load and restrictions on the blade, such as fastening one end and exerting a force or torque at the other, are examples of this. In ANSYS, the process of doing a blade static structure analysis entails the creation of a 3D geometry, mesh generation, assignment of material and property values, application of boundary conditions, analysis of the structure, and visualization of the outcomes.

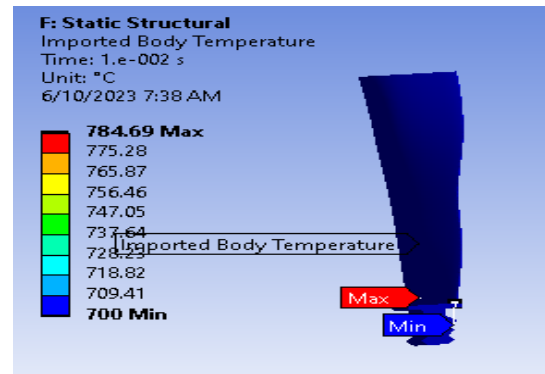

a. The static structural analysis applied Imported thermal loads

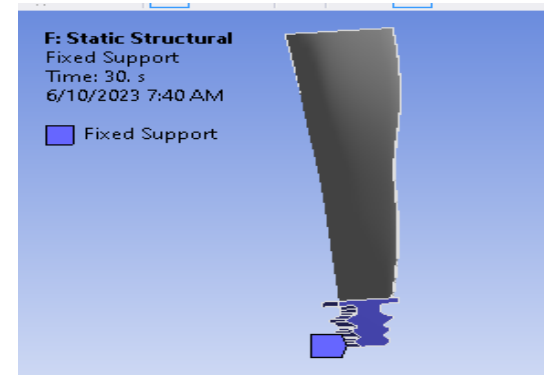

b. The Static structural analysis applied for support on root  
Fig. 19 The 3D static structural analysis applied Imported thermal loads

Static structural analysis can offer important insights into the structural stability and integrity of the root system when used to support a root (Fig. 19). The study considers elements including the root's material characteristics, the applied loads, and the boundary conditions. Typically, the root system is modeled using finite elements as part of the investigation. The behavior of each of the microscopic pieces that make up the root is determined using mathematical equations that show how forces, displacements, and material qualities relate.

### 5. Blade Elastic Strain

When a blade is subjected to a load, ANSYS blade elastic strain is the deformation or lengthening of those results. For structural analysis and simulation, including blade analysis, ANSYS is a potent software tool. A blade's elastic strain is calculated by ANSYS using information about the material's characteristics, shape, and loading circumstances. Typically, we would start by building a 3D model of the blade in order to study the elastic strain of the blade in ANSYS. All pertinent geometric information, including the blade's thickness, width, length, and any curvature or tapering, should be included in this model.

The elastic strain in the blade would then be determined by ANSYS using a finite element analysis (FEA) after the loads had been applied. The blade is divided into several tiny, linked elements using the finite element approach by ANSYS, which then examines each element's behavior under the imposed stresses. After the analysis is finished, ANSYS produces a thorough report that details the maximum elastic strain as well as the location and size of any problem areas. The blade's design can then be optimized in order to enhance its functionality and lengthen its lifespan.

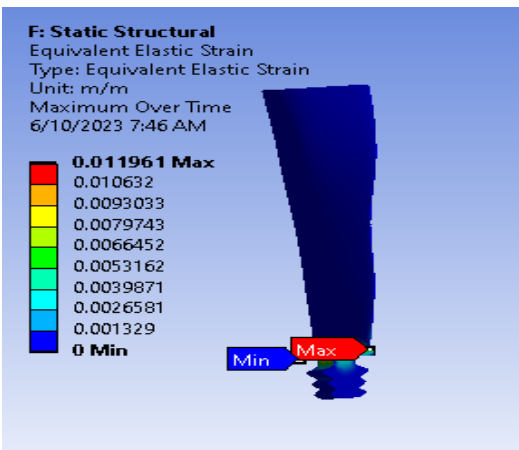

Fig. 20 3D Blade Elastic Strain

The term “equivalent elastic strain” in structural analysis refers to a condensed illustration of the strain distribution in a structure under static loading circumstances. It is frequently used in linear elastic analysis to gauge a structure's reaction and behavior in Fig. 20.

Each component or site in the structure is given an equivalent elastic strain value, a scalar number representing the strain that would have the same result as the actual distribution of stresses brought on by applied loads.

### D. Fatigue Blade Structure

#### 1. Fatigue Tool of Blade Structure

Using the required elements and boundary conditions, create a finite element model of the structure in ANSYS. Describe the structure's material characteristics. These qualities ought to include fatigue ductility, fatigue strength, and endurance limits. Define the structure's loading requirements. These specifications ought to cover the frequency, amplitude, and mean stress. Establish the kind of fatigue analysis, the fatigue criteria, and the safety factor to set up the fatigue analysis in ANSYS.

For reliable results, mesh the model using the proper meshing procedures. To determine the stress or strain cycles at each element, solve the model using ANSYS. Extraction of the stress or strain cycles at key places in the structure and analysis of the findings using fatigue criteria. For reliable results, mesh the model using the proper meshing procedures. To determine the stress or strain cycles at each element, solve the model using ANSYS. A zero-based loading method was chosen, and the stress component was chosen as equivalent to von Mises or based on mean stress correction theory.

Extraction of the stress or strain cycles at key places in Fig. 21, the structure and analysis of the findings using fatigue criteria Analyze the outcomes. To decide if the structure is secure under the specified loading circumstances, evaluate the results of the fatigue analysis. In conclusion, by using ANSYS and the procedures listed above, fatigue analysis of structures may be performed. It is crucial to remember that fatigue analysis is a difficult technique that needs skill and experience to get reliable results.

#### 2. Blade with a Biaxiality Indicator

A material or structure is said to be biaxially loaded when it is subjected to two separate, perpendicular sets of stresses or strains. Depending on the type of study and the intended outcome, biaxiality may be expressed in ANSYS in a number of different ways. In ANSYS, biaxiality is often determined by looking at the main stresses and strains in the structure. The highest and minimum normal stresses at a certain site are known as the primary stresses and the associated strains are known as the major strains. The structure is under biaxial stresses or strains if the highest and least primary stresses or strains are both nonzero. A biaxial loading test, in which the structure is exposed to two separate and perpendicular loads, is another method for analyzing biaxiality in ANSYS.

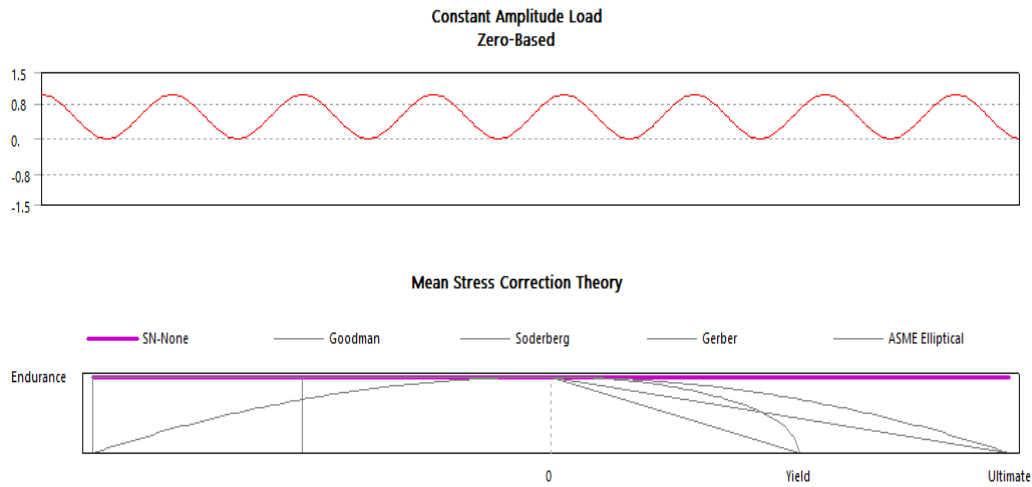

Fig. 21 3D Fatigue tool

To do this, define two distinct loads in the Load step and indicate their magnitudes and orientations. The study that follows will demonstrate how the structure reacts to the biaxial stress, including any alterations in stiffness, strength, or deformation. The indication of biaxiality in ANSYS often depends on the precise analysis being done and the intended outcome. It is possible to establish whether a structure is experiencing biaxial stresses or strains and to see the distribution of these stresses and strains throughout the structure by looking at the primary stresses and strains as well as biaxial loading experiments.

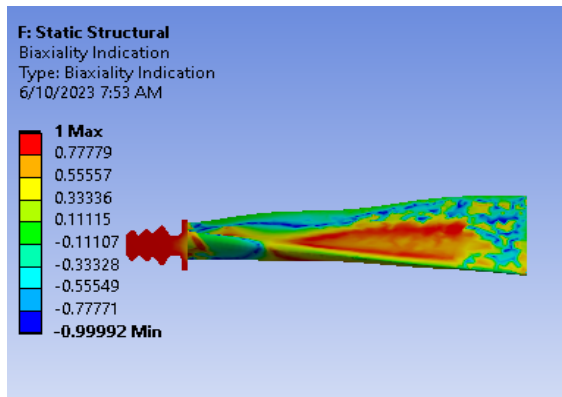

Fig. 22 3D Blade biaxiality indicator

Biaxiality in engine blades as shown in Fig. 22, can relate to a number of characteristics, including stiffness, strength, or responsiveness to stresses applied in several directions. The indicator stated most likely seeks to gauge or quantify the engine blades' 3D biaxial activity. Blade with a biaxiality indicator here fatigue life error. An engine blade may undergo fatigue failure, which is the slow deterioration of the material as a result of the repetitive application of stress if it is subjected to several loading cycles. An incorrect estimate of the biaxiality indicator might result in inaccurate predictions regarding the fatigue life of the engine blade. For instance, if the biaxiality indication is exaggerated, it might result in a miscalculation of the fatigue life and cause the blade to break sooner than it should.

### 3. Fatigue Sensitivity on Blade Structure

For the engine blade fatigue sensitivity study in ANSYS, cyclic loading conditions are simulated, and the ensuing stress and strain responses are assessed. These are the steps involved in this process: Create the engine blade's material attributes in ANSYS. Make an engine blade finite element model and use cyclic loading criteria. Calculate the maximum stress that the blade endured during the cyclic loading by doing a stress analysis. Calculate the blade's fatigue life using the maximum stress values and fatigue analysis methodologies like S-N curves or damage accumulation methods. To ascertain the impact of different design parameters on the fatigue life of the blade, do a sensitivity analysis.

Use ANSYS Workbench or ANSYS Mechanical to carry out a fatigue sensitivity study. In order to simulate and study the behavior of engine blades under cyclic loading circumstances, each of these programs includes a number of functions. We may also do fatigue life estimates and sensitivity analysis with the use of ANSYS's numerous fatigue analysis tools, including the Fatigue Toolkit and the ANSYS nCode Design Life. It's crucial to remember that fatigue sensitivity analysis is a difficult process that calls for proficiency in both ANSYS and fatigue analysis.

The connection between the stress amplitude (S) and the number of cycles to failure (N) of material under cyclic loading circumstances is shown graphically by the S-N curve. The process of repeatedly loading and unloading a material until it fails in order to create the curve is known as fatigue testing. The S-N curve is crucial for engineering design because it sets acceptable operating limits for cyclic loads and aids in determining the fatigue life of a material or component. In Fig. 23, the S-N curve's cycle limit denotes the point at which a material can no longer resist the stress amplitude and will eventually break after a certain number of cycles. This upper limit is also known as the fatigue strength limit or the fatigue endurance limit.



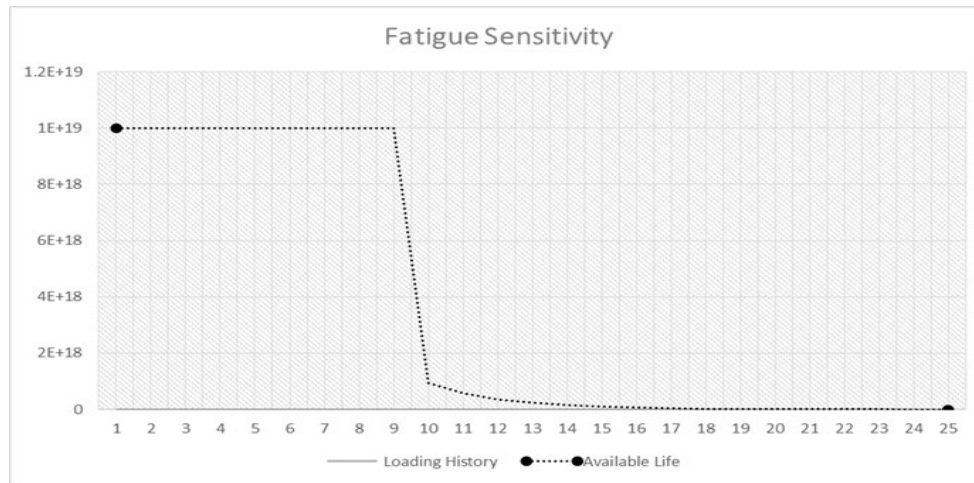

Fig. 23 3D Blade Structure Fatigue Sensitivity

#### 4. Fatigue Lifetime 3D Engine Blade Structure

The fatigue life analysis of the turbine blade using ANSYS software yielded valuable insights into its durability under cyclic loading conditions. The analysis involved a coupled approach, combining the ANSYS Thermal and Static Structural modules to account for the thermal and mechanical effects on the blade's fatigue behavior.

The fatigue life data obtained from the analysis provides crucial information about the blade's ability to withstand cyclic loading and potential failure mechanisms. The analysis revealed that the turbine blade has a fatigue life of approximately  $1e19$  cycles before failure, based on the applied loading conditions and material properties.

The fatigue life curve obtained from the analysis shows a gradual decrease in the blade's fatigue strength over the cycles. This trend indicates the progressive accumulation of damage within the blade material, leading to eventual failure. The fatigue strength, defined as the maximum stress level the blade can withstand without failure, was found to be  $9.1998e8$  Pa.

Comparing the obtained fatigue life data with industry standards and design criteria, it is evident that the blade's fatigue performance meets the desired requirements. The turbine blade's fatigue life aligns with the expected operational lifespan and ensures reliable performance under cyclic loading conditions typically experienced in gas turbine engines. The analysis also highlighted certain factors influencing the fatigue life of the turbine blade.

Stress concentrations were observed at specific regions, such as near the blade's root and leading edge, which significantly influenced the fatigue response. These areas experienced higher stress levels due to the complex geometry and loading conditions. Future design improvements should focus on reducing stress concentrations in these critical regions to enhance the blade's fatigue life.

Temperature gradients within the blade were another influential factor identified in the analysis. The thermal analysis revealed varying temperature distributions throughout the blade, with higher temperatures observed near the hot gas path. These temperature gradients impact the blade's fatigue life by inducing thermal stresses and promoting material degradation. Proper thermal management techniques, such as enhanced cooling strategies or advanced thermal barrier coatings, could be employed to mitigate these effects and improve fatigue performance.

The obtained fatigue life data provides a foundation for optimizing the turbine blade's design and maintenance strategies. By understanding the blade's fatigue behavior, engineers can make informed decisions to enhance its reliability and performance. Sensitivity analyses can be conducted within ANSYS to explore the impact of design modifications or material changes on the blade's fatigue life. These analyses aid in identifying critical parameters and facilitate the development of more durable turbine blades.

In conclusion, the fatigue life analysis using ANSYS software provided valuable insights into the durability of the turbine blade. The obtained fatigue life data, encompassing the number of cycles to failure and fatigue strength, demonstrated that the blade meets the required performance criteria. By addressing stress concentrations and optimizing thermal management techniques, the blade's fatigue life can be further improved, ensuring reliable operation and prolonging its lifespan in gas turbine engines. To assure its dependability and safety, the design of a fatigue-resistant 3D engine blade construction incorporates a number of factors. The material choice greatly influences the blade's fatigue life. The blade's form and design must be improved to lower stress concentrations, reduce weight, and boost strength. Some design elements that can increase the blade's fatigue life include the use of fillets, rounding of corners, and optimizing the cross-sectional area. Shot peening, which includes pelting the blade surface with tiny, fast-moving particles, can produce compressive stresses that boost the blade's resistance to fatigue.

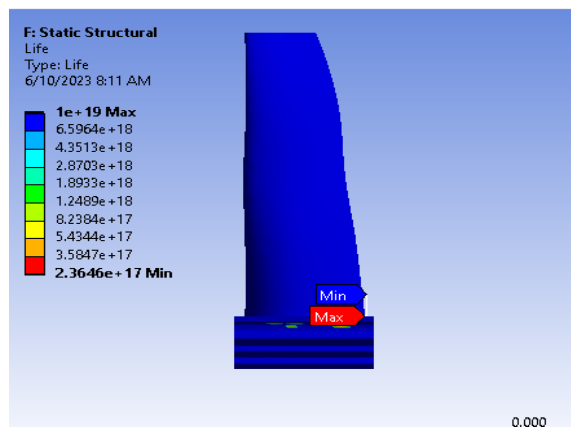

Fig. 24 Fatigue lifetime 3D Blade Structure

Fatigue lifetime is the time or number of cycles that the blades can withstand before failing from fatigue in Fig. 24 of a 3D blade structure, such as those seen in gas turbines or aviation engines. A fatigue-resistant 3D engine blade construction was created to satisfy the strict specifications of contemporary aviation engines. It is crucial to ensure the safety of a fatigue-resistant 3D engine blade construction since any blade failure might have disastrous effects. To make sure it satisfies the criteria for fatigue resistance and strength, the material used in the blade is put through rigorous testing. Tensile, compression, and fatigue testing are a few of these tests. To confirm that the blade design can handle the pressures and strains it will be exposed to during operation, computer simulations, and physical tests are used to validate the design. Before the blade is put into service, any flaws or design deviations are found and fixed. Non-destructive testing methods are used on the blade on a regular basis to check for any flaws or cracks that might appear while it is in use. A fatigue life of 1019 on the upper part of the blade and lowest on the lower part of the blade surface.

According to the manufacturer's guidelines, the blade is routinely inspected and maintained to make sure it remains in good condition and any possible problems are found and fixed before they endanger users. These safety precautions can be put in place to guarantee the dependability and security of a fatigue-resistant 3D engine blade structure, giving those who operate and maintain aircraft powered by such an Engine peace of mind.

## V. CONCLUSION

In conclusion, this research project focused on the fatigue analysis of aero engine turbine blades using the finite element method while considering thermal load. The study began by discussing the design of the turbine blade using the point cloud method, which provided a solid foundation for further analysis. To model and simulate the problems, ANSYS Workbench was employed, allowing for accurate representation and evaluation of the blade's behavior under different operating conditions. The state-of-the-art thermal and static structural solver, Stade, was utilized to solve the problem, providing valuable insights into the blade's

performance. The results of the analysis revealed a significant amount of heat stress and deformation near the blade's fir tree root joint. This finding highlights the importance of considering thermal load in the design and maintenance of turbine blades. By identifying these areas of concern, appropriate measures can be taken to mitigate the risk of fatigue failure and ensure the longevity and reliability of the turbine blades. Overall, this research project contributes to the understanding of fatigue analysis in aero engine turbine blades and emphasizes the significance of incorporating thermal load considerations. The findings serve as a valuable resource for engineers and researchers in the field, aiding in the development of more robust and efficient turbine blade designs.

## REFERENCES

- [1] E. Poursaeidi, M. Aieneravaie and M. R. Mohammadi, "Failure analysis of a second stage blade in a gas turbine engine," *Engineering Failure Analysis*, Vol. 15, No. 8, pp. 1111-1129, 2008.
- [2] J. Hour, B. J. Wicks and R. A. Antoniou, "An investigation of fatigue failures of turbine blades in a gas turbine engine by mechanical analysis," *Engineering Failure Analysis*, Vol. 9, No. 2, pp. 201-211, 2002.
- [3] N. P. Padture, M. Gell and E. H. Jordan, "Thermal barrier coatings for gas-turbine engine applications," *Science*, Vol. 296, pp. 280-284, 2002.
- [4] D. R. Clarke and C. G. Levi, "Materials design for the next generation thermal barrier coatings," *Annual Review of Materials Research*, Vol. 33, pp. 383-417, 2003.
- [5] W. Z. Tang, L. Yang, W. Zhu, Y. C. Zhou, J. W. Guo and C. Lu, "Numerical simulation of temperature distribution and thermal-stress field in a turbine blade with multilayer-structure TBCs by a fluid-solid coupling method," *Materials Science and Technology*, Vol. 32, No. 5, pp. 452-458, 2016.
- [6] Z. Y. Yu, S. P. Zhu, Q. Liu and Y. Liu, "A new energy-critical plane damage parameter for multiaxial fatigue life prediction of turbine blades," *Materials*, Vol. 10, pp. 513, 2017.
- [7] S. Rani, A. K. Agrawal and V. Rastogi, "Failure analysis of a first stage IN738 gas turbine blade tip cracking in a thermal power plant," *Case Studies in Engineering Failure Analysis*, Vol. 8, pp. 1-10, 2017.
- [8] H. Chung, H. Sohn, J. S. Park, K. M. Kim and H. H. Cho, "Thermo-structural analysis of cracks on gas turbine vane segment having multiple airfoils," *Energy*, Vol. 118, pp. 1275-1285, 2017.
- [9] S. Qu, C. M. Fu, C. Dong, J. F. Tian and Z. F. Zhang, "Failure analysis of the 1st stage blades in a gas turbine engine," *Engineering Failure Analysis*, Vol. 32, pp. 292-303, 2013.
- [10] A. Carpinteri, E. Macha, R. Brighenti, *et al.*, "Expected principal stress directions under multiaxial random loading, Part I: Theoretical aspects of the weight function method," *International Journal of Fatigue*, Vol. 21, pp. 83-88, 1999.
- [11] P. Evans, N. Owen and L. McCartney, "Mean stress effects on fatigue crack growth and failure in rail steel," *Engineering Fracture Mechanics*, Vol. 6, pp. 183-193, 1974.
- [12] A. Pogorelov, M. Meinke and W. Schröder, "Large-eddy simulation of the unsteady full 3D rim seal flow in a one-stage axial-flow turbine," *Flow, Turbulence and Combustion*, Vol. 102, pp. 189-220, 2019.
- [13] P. Brandão, V. Infante and A. M. Deus, "Thermo-mechanical modeling of a high-pressure turbine blade of an airplane gas turbine engine," *Procedia Structural Integrity*, Vol. 1, pp. 189-196, 2016.
- [14] E. Poursaeidi, M. Aieneravaie and M. Mohammadi, "Failure analysis of a second stage blade in a gas turbine engine," *Engineering Failure Analysis*, Vol. 15, pp. 1111-1129, 2008.
- [15] M. P. Boyce, *The gas turbine handbook*, 2nd ed. Houston, Texas: Gulf Professional Publishing, Vol. 368, 2002.
- [16] J. G. Marshall and A. Imregun, "A review of aeroelasticity methods with emphasis on turbomachinery applications," *Journal of Fluids and Structures*, Vol. 10, pp. 237-265, 1996.

- [17] M. A. Miner, "Cumulative damage in fatigue," *Journal of applied mechanics*, Vol. 67, pp. A159-A164, 1945.
- [18] A. Fatemi, Yang Lianxiang, "Cumulative fatigue damage and life prediction theories: A survey of state of the art for homogeneous materials," *International Journal of Fatigue*, Vol. 20, No. 1, pp. 9-34, 1998.
- [19] Y. N. Rabotnov, "On the equations of state for creep," *Progress in Applied Mechanics*, Vol. 178, No. 3A, pp. 117-122, 1963.
- [20] L. M. Kachanov, "Rupture time under creep conditions," *International Journal of Fracture*, Vol. 97, No. 1-4, pp. 11-18, 1999.
- [21] S. M. Marco and W. L. Starkey, "A concept of fatigue damage," *Transactions of the ASME*, Vol. 76, pp. 627-32, 1954.
- [22] Z. Chen, J. Li, J. Liao, and F. Shi, "Stress and fatigue analysis of engine pistons using thermo-mechanical model," *Journal of Mechanical Science and Technology*, Vol. 33, No. 9, pp. 4199-4207, 2019.
- [23] D. L. Li, Y. F. Yin, G. F. Chen, C. Cui, and B. Han, "Thermal fatigue analysis of the engine exhaust manifold," *Advanced Materials Research*, Vol. 482-484, pp. 214-219, 2012.
- [24] L. Schwerdt *et al.*, "Aerodynamical and structural analysis of operationally used turbine blades," *Procedia CIRP*, Vol. 59, pp. 77-82, 2017.
- [25] B. L. Liu, *High-frequency flow, structure interaction in dense subsonic fluids*, NASA Contractor Report, SuDoc NAS 1.25:194007/NAS8-38187, Rockwell, 1994.
- [26] E. H. Brummelen, *The added mass effect of compressible and incompressible flows in fluid-structure interaction*, Report of TU Delft DACS-09-001, Netherlands, 2009.
- [27] C. Forster, W. A. Wall and E. Ramm, "Artificial added mass instabilities in the sequential staggered coupling of nonlinear structures and incompressible viscous flows," *Computer Methods in Applied Mechanics and Engineering*, Vol. 196, pp. 1278-1293, 2007.