

Design & Analysis of Hybrid Micro Grid with DC Connection at Back to Back Converter

S.P.Aravind¹ and E.Darwin Suthar²

¹Final Year PG student, ²Assistant Professor, Department of Electrical & Electronics Engineering,

Maria College of Engineering & Technology, Marthandam - 629177, Tamil Nadu, India

E-mail: sparavind@live.com

(Received on 05 May 2014 and accepted on 10 June 2014)

Abstract - A micro grid is a localized grouping of electricity generation, energy storage, and loads that normally operate connected to a traditional centralized grid (macro grid). This single point of common coupling with the macro grid can be disconnected. The micro grid can then function autonomously. Generation and loads in a micro grid are usually interconnected at low voltage. From the point of view of the grid operator, a connected micro grid can be controlled as if it were one entity. Micro grid generation resources can include fuel cells, wind, solar, or other energy sources. The necessity of an AC or DC micro grid is governed by available micro sources and connected loads. A hybrid structure can ensure a sustainable configuration blending both the forms. In this paper, a hybrid micro grid structure for a grid connected micro grid with DC connection at back to back (B2B) converters is proposed. While a B2B connection between two AC systems could bestow a reliable, isolated and efficient coupling, an extra DC bus connection can facilitate use of the DC micro sources. The DC bus can supply the local DC loads and can also trade part of the power with the AC grids. The voltage support at the DC link (of the B2B converters) can be used for the DC bus formation. Different power management strategies with fixed power references or decentralized power distribution in AC/DC sides are proposed and validated with simulations in MATLAB.

Keywords: Micro Grid, B2B Connection, DC Loads, MATLAB

I. INTRODUCTION

As electric distribution technology steps into the next century, many trends are becoming noticeable that will change the requirements of energy delivery. These modifications are being driven from both the demand side where higher energy availability and efficiency are

desired and from the supply side where the integration of distributed generation and peaks having technologies must be accommodated.

Power systems currently undergo considerable change in operating requirements mainly as a result of deregulation and due to an increasing amount of distributed energy resources (DER). In many cases DERs include different technologies that allow generation in small-scale (micro sources) and some of them take advantage of renewable energy resources (RES) such as solar, wind or hydro energy. Having micro sources close to the load has the advantage of reducing transmission losses as well as preventing network congestions. Moreover, the possibility of having a power supply interruption of end-customers connected to a low voltage (LV) distribution grid is diminished since adjacent micro sources, controllable loads and energy storage systems can operate in the islanded mode in case of severe system disturbances. This is identified nowadays as a micro grid. The distinctive micro grid has the similar size as a low voltage distribution feeder and will rarely exceed a capacity of 1MVA and a geographic span of 1 km. Generally more than 90% of low voltage domestic customers are supplied by underground cable when the rest is supplied by overhead lines. The micro grid often supplies both electricity and heat to the customers by means of combined heat and power plants (CHP), gas turbines, fuel cells, photovoltaic (PV) systems, wind turbines, etc. The energy storage systems usually include batteries and flywheels. The storing device in the micro grid is equivalent to the rotating reserve of large generators in the conventional grid which ensures the balance between energy generation and consumption especially during rapid changes in load or generation.

From the customer point of view, micro grids deliver both thermal and electricity requirements and in addition improve local reliability, reduce emissions, improve power excellence by supportive voltage and reducing voltage dips and potentially lower costs of energy supply. From the utility viewpoint, application of distributed energy sources can potentially reduce the demand for distribution and transmission facilities. Clearly, distributed generation located close to loads will reduce flows in transmission and distribution circuits with two important effects: loss reduction and ability to potentially substitute for network assets. In addition, the presence of generation close to demand could increase service quality seen by end customers. Micro grids can offer network support during the time of stress by relieving congestions and aiding restoration after faults. The development of micro grids can contribute to the reduction of emissions and the mitigation of climate changes. This is due to the availability and developing technologies for distributed generation units are based on renewable sources and micro sources that are characterized by very low emissions.

There are various advantages offered by micro grids to end-consumers, utilities and society, such as: improved energy efficiency, minimized overall energy consumption, reduced greenhouse gases and pollutant emissions, improved service quality and reliability, cost efficient electricity infrastructure replacement. Technical challenges linked with the operation and controls of micro grids are immense. Ensuring stable operation during network disturbances, maintaining stability and power quality in the islanding mode of operation necessitates the improvement of sophisticated control strategies for micro grid's inverters in order to provide stable frequency and voltage in the presence of arbitrarily varying loads. Nevertheless, there are various technical issues associated with the integration and operation of micro grid.

Protection system is one of the major challenges for micro grid which must react to both main grid and micro grid faults. The protection system should cut off the micro grid from the main grid as rapidly as necessary to protect the micro grid loads for the first case and for the second case the protection system should isolate the smallest part of the micro grid when clears the fault. A segmentation of micro

grid, i.e. a design of multiple islands or sub micro grids must be supported by micro source and load controllers. In these conditions problems related to selectivity (false, unnecessary tripping) and sensitivity (undetected faults or delayed tripping) of protection system may arise. Mainly, there are two main issues concerning the protection of micro grids, first is related to a number of installed DER units in the micro grid and second is related to an availability of a sufficient level of short-circuit current in the islanded operating mode of micro grid since this level may substantially drop down after a disconnection from a stiff main grid. The directions and amplitudes of short circuit currents will vary because of these conditions. In reality the operating conditions of micro grid are persistently varying because of the intermittent micro sources (wind and solar) and periodic load variation. Also the network topology can be changed frequently which aims to minimize loss or to achieve other economic or operational targets. In addition controllable islands of different size and content can be formed as a result of faults in the main grid or inside micro grid. In such situations a loss of relay coordination may happen and generic OC protection with a single setting group may become insufficient, i.e. it will not guarantee a selective operation for all possible faults. Hence, it is vital to ensure that settings chosen for OC protection relays take into account a grid topology and changes in location, type and amount of generation. Otherwise, unwanted operation or failure may occur during necessary condition.

The widespread interconnection of distributed generators (DGs) has created possibility of micro grid, both in AC and DC forms. Combining both AC and DC systems, hybrid micro grid has been proposed by many researchers [1]–[12]. The presence of AC and DC sources requires detail investigation of the control aspects in such systems. The power sharing issues in a hybrid micro grid is investigated in [1]. The authors have identified that the main challenge in such micro grid structure is to manage power flows among all sources distributed in the AC and the DC grids. Suitable control schemes are proposed for such system. The coordination control algorithms are proposed in [2] to balance the power flow between the AC and the DC grids and to maintain both the DC and the AC voltages. Another efficient AC/DC micro grid structure is presented in [3]; where the hybrid grid is consist of AC

and DC network connected through multi bidirectional converters. The coordination control algorithms are proposed for smooth power transfer between AC and DC links and for stable system operation under various generation and load conditions. In [4], an assessment and mitigation strategies for system level dynamic interaction (to achieve tight regulation of load requirement) with control power converters is investigated in a hybrid micro grid. An effective control method to reshape the DC side admittance is proposed to improve the system stability. In [5], a real-time circulating current reduction method, for parallel harmonic-elimination pulse width modulation (HEPWM) inverters used to employ power transfer between AC and DC buses in hybrid micro grid, is proposed. The proposed method can provide an extra 15% modulation index range which is a great benefit for power converter applications in this area. The stability issues in a hybrid micro grid are very well addressed in [6], [7]. The proposed control schemes improve the voltage stability in the DC bus and the efficacy of the controller is verified considering the uncertainty of the generators and loads existed in micro grid. In [8], different effective and simple control strategies for hybrid AC-DC micro grid (both grid-connected and islanded operations) are described. The proposed control can keep the power balance and ensures stable AC/DC bus. A micro grid paradigm with both DC and AC links, which may provide an effective way to integrate a heterogeneous set of small-size distributed energy, is also presented [9]. A decoupled control framework is developed for the hybrid micro grid and the performances are evaluated. The power electronics interfaces and controls for a micro grid with both DC and AC links are investigated in [10]. A general framework to aggregate a wide range of distributed energy resources at several levels with DC, AC, and synchronous links is proposed with variety of power electronics interfaces and control schemes. The energy management system in an AC and DC bus linked micro- grid, is described in [11] for different operating modes. The need of frequency and voltage control is identified along with the DC bus voltage. A centralized power control scheme for a hybrid micro grid is proposed in [12]. The proposed scheme controls the power flow of the multiple AC-DC bidirectional converters connected in parallel that connect AC and DC buses.

The key issues identified by many authors are

- Power sharing in hybrid structure.
- AC and DC bus voltage stability.
- Power exchange between the AC and DC bus.
- Power quality and system reliability.

The power management system plays a crucial role in any micro grid and can ensure improved steady state performance [13]–[18]. A generalized formulation for intelligent energy management of a micro grid with linear programming based multi objective optimization is proposed in [13]. The results show the efficacy of the proposed method to minimize the operation cost and emission level. A hierarchical active power management strategy for a medium voltage (MV) islanded micro grid is proposed in [14]. The DGs use an adaptive proportional resonance (PR) controller for regulating the load voltage, and a droop control strategy for average power sharing among the DG units. In [15], a centralized control system for different DGs inverters within a micro grid is proposed. A new model predictive control algorithm is used for faster computational time for large systems by optimizing both the steady-state and the transient controls. An Energy Management System for the optimal operation of smart grids and micro grids is proposed in [16]. An adaptive algorithm based on advanced control techniques is used to allow energy saving, customers participation in the market etc. A two level architecture for distributed energy resource management for multiple micro grids using multi agent systems (MAS) is proposed in [17]. A central power-management system (PMS) with a decentralized, robust control strategy for autonomous mode of operation of a micro- grid is proposed in [18]. A GPS system is used to synchronize the oscillators of the Voltage Source Converter (VSC) DGs.

The aim of each power management strategies is to

- Optimized use of the micro sources.
- Stable control strategies in secondary level.
- Advanced control techniques for power management and synchronized operations.

The power flow management in a utility connected micro grid through back to back (B2B) converters is investigated

in [19]. The frequency and voltage isolation with controlled power flow provides reliable system operation.

In this paper, a hybrid micro grid structure with DC bus connection at B2B converter is proposed. The main contribution of this paper lies in enabling this new hybrid structure for grid connected micro grid through B2B converters. The controlled power flows between the micro grids and utility provide a new system model (and business) for hybrid micro grid. Different control modes and power flow strategies are developed to demonstrate the efficacy of the proposed micro grid structure and associated controls.

II. SYSTEM STRUCTURE

The basic system structure is shown in Fig. 1. The AC micro- grid with two DGs (DG-1 and DG-2) and one load is connected to the utility through B2B converters. The DGs are interfaced through VSC-3 and VSC-4. The DG interfacing VSCs (in AC micro grid) convert the DC output of the DGs to AC. The B2B is made of two VSCs (VSC-1 and VSC-2) with common DC link as shown. Two DGs (DG-3 and DG-4) are connected at the DC side of the B2B converters. The DGs in DC micro grid are interfaced through DC to DC converter (DC/DC) as shown in Fig. 1. The DC/DC converter boosts the DC voltage output of the DGs to DC bus voltage level.

In this structure,

- B2B can provide isolation of the AC micro grid and voltage support for the DC micro grid.
- Direct connection of few DC micro sources at the DC bus is achieved.
- Power flow management for the AC and DC micro grid is established.

There are few possible control modes of the system. While VSC-1 is always responsible to hold the DC voltage,

- The DC/DC converters can be on,
 - Power control mode based on MMPT.
 - Droop control with other DC sources.
- Droop based on their own voltage.
- Droop based on B2B DC bus voltage.

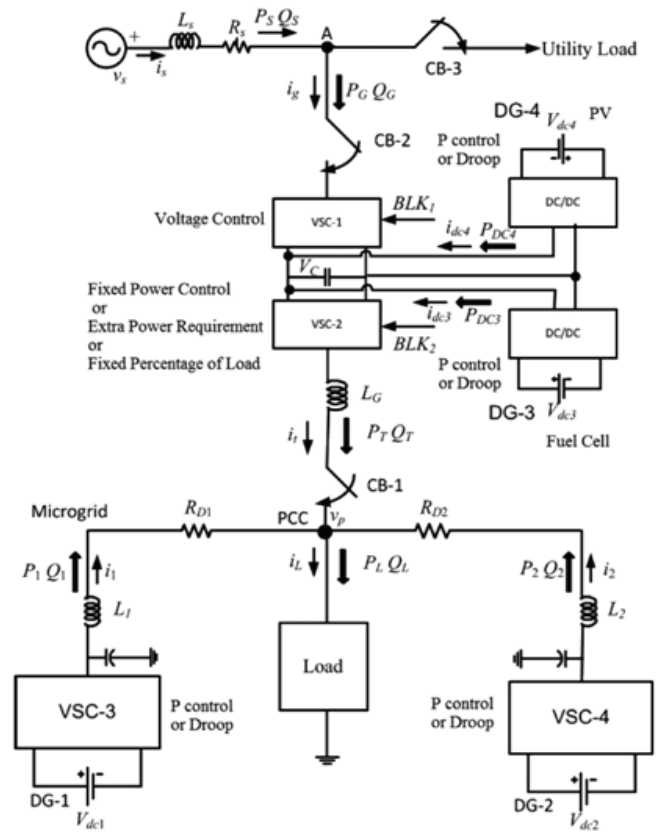

Fig. 1 System structure with AC/ DC micro grids

- AC micro grid converters can operate
 - Voltage output angle control (droop)-Mode1
 - Fixed Power (PQ) mode-Mode2.
- VSC-2 of the B2B
 - Can operate with fixed power in either direction (to or from AC micro grid)-Mode1.
 - Can operate with output voltage angle control (droop)- Mode2.

It is possible to supply DC loads from the DC bus and the power output of the DC sources are represented as P_{DCi} (of the i^{th} DG). The power from the utility is P_G, Q_G and power to the AC micro grid is P_T, Q_T .

- Supply a fixed amount power from utility to AC micro grid or vice versa.
- Supply the extra power requirement from utility to AC micro grid (or excess power from AC micro grid to utility) in Mode-1 operation.

- Provide the DC voltage support for the DC micro grid and supply limited power (based on control limit).
- Supply excess power from DC micro grid to the AC micro- grid.
- Supply the excess power from AC micro grid to DC micro- grid with the voltage control at the DC bus.

III. CONTROL OF DC MICROGRID

The utility interfacing VSC (VSC-1) controls the DC voltage while the DC micro sources may operate in fixed power control or droop control mode. The current reference of the DC micro sources operating in constant P control can be derived as

$$I_{FCref} = \left(K_{pp} + \frac{K_{ipp}}{s} \right) (P_{dref} - P_{dmeas}) \quad (1)$$

For droop control operation, the current reference is calculated as

$$I_{FCref} = \left(K_{pp} + \frac{K_{ipp}}{s} \right) \times (V_{drated} - V_{dmeas} - K_{DRP}(P_{dref} - P_{dmeas})) \quad (2)$$

It must be noted that of DC micro source with storage can be controlled with respect to output power or to accommodate sudden small change in power requirement. The output voltage (or current) is used to feed the micro source dynamic model while the output current (or voltage) is used as the input to the control scheme. The control block provides the reference input to the voltage (or current) source.

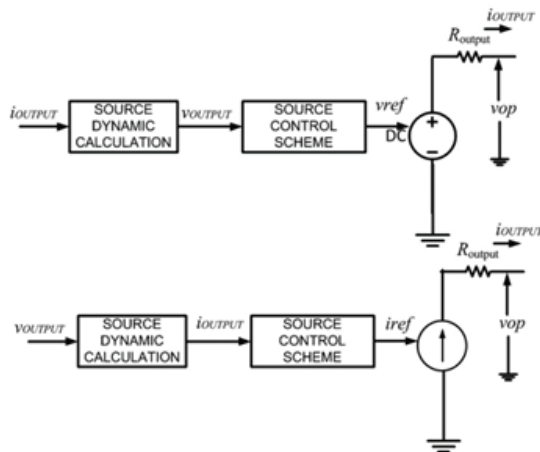

Fig. 2 Control schemes of the DC micro sources

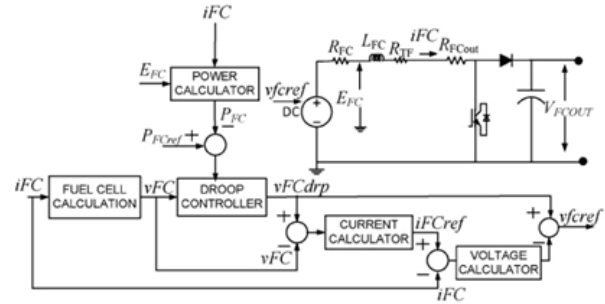

Fig. 3 Control scheme of the fuel cell

In this model fuel cells and PVs are considered as the DC micro sources. The source dynamics of the fuel cell and PV play an important role in the system response. The fuel cell is represented with the VI characteristic while power conditioning units are modeled with DC chopper a proper design of the chopper should be followed depending on the system requirement and chopper structure. The output current (i_{FC}) and output voltage (E_{FC}) are used to calculate the output power. The output current is also used in the fuel cell voltage calculation. The droop controller calculates the output voltage reference (v_{FCdrp}). The error in the voltage is passed through the PI controller to calculate the current reference. The error in current is used to modify the reference input voltage (through a PI control) of the DC source.

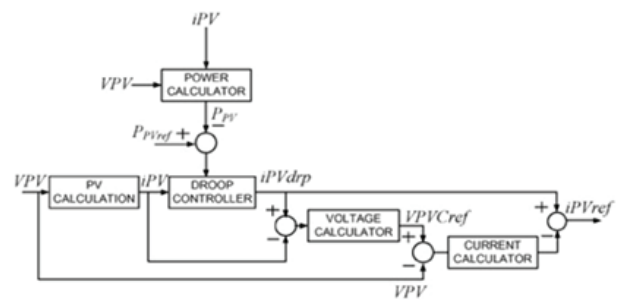

Fig. 4 Control scheme of the PV

The control scheme of the PV module is similar to the control scheme of the fuel cell. Similarly the PV source control is implemented with current driven model.

IV. CONTROL OF AC MICROGRID

It is assumed that only VSC interfaced micro sources are present in the AC micro grid. However, the proposed

method can also accommodate inertial DGs. The DGs in AC micro grid are VSC interfaced and they are represented by ideal DC sources. The power set points and measured powers are used to calculate the limited power reference. The power errors are fed to the power controller to derive the current references. The voltage reference is then calculated based on the measured current, measured voltage and current reference values. The frequency and voltage regulation are achieved at the last control block with measured output powers.

The voltage references are calculated as

$$V_{dref} = \left(K_{vdac} + \frac{K_{ivdac}}{s} \right) (I_{dref} - I_{dmeas}) + V_{dmeas} + I_{dmeas}R_{tr} + I_{qmeas}X_{tr} \quad (3)$$

$$V_{qref} = \left(K_{vqac} + \frac{K_{ivqac}}{s} \right) (I_{qref} - I_{qmeas}) + V_{qmeas} + I_{qmeas}R_{tr} + I_{dmeas}X_{tr} \quad (4)$$

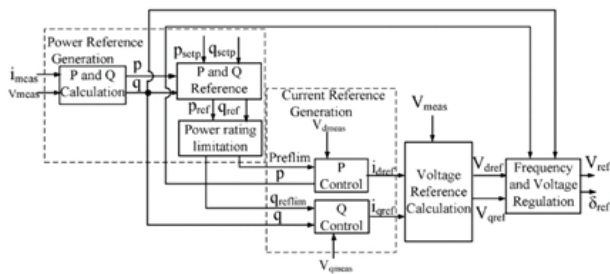

Fig. 5 Control layout of the VSC interfaces micro sources

V. CONTROL OF BACK TO BACK CONVERTERS

VSC-1 controls the voltage in the DC bus to a predefined magnitude and control of VSC-1 output voltage angle is achieved as

$$\delta_{ref} = \left(K_{vdc} + \frac{K_{vidc}}{s} \right) (V_{dcref} - V_{dcmeas_{av}}) \quad (5)$$

VSC-2 can be controlled to supply:

A fixed power from AC micro grid to the DC bus;

A fixed power to AC micro grid from the DC bus;

Extra power requirement of the AC micro grid in droop control mode.

For supplying fixed power in either direction, the PCC of the AC micro grid is used as the point of reference.

VI. POWER FLOW MANAGEMENT

Bidirectional controlled power flow between the AC micro grid and utility facilitates different control scenario. As the B2B provides the voltage controlling bus for the DC micro grid, the DGs in DC micro grid can operate in fixed power or droop control mode. The power exchange between the micro grids depends on the control mode and power requirements

- In droop control mode, the power sharing is decided based on the droop coefficients.
- If the B2B supplies fixed power or fixed percentage of load power, the rest of the power requirement is shared among the AC micro grid DGs with droop equations.

The proposed integrated system structure can operate in different control modes.

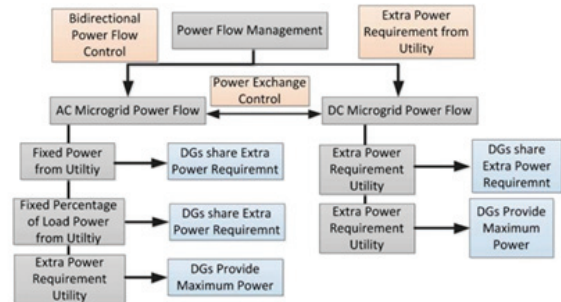

Fig. 6 Power flow management of the proposed method

In this model we are considering two operating scenarios:

Case 1: In this case a fixed power is supplied from the utility to the AC micro grid (or vice versa) and voltage control is achieved for the DC micro grid. As the power from the AC grid is controlled in this case, it is more suitable for a contractual scenario with the AC micro grid.

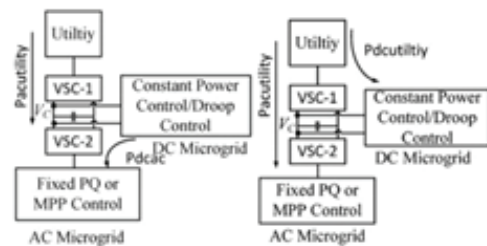

Fig. 7 Power flow schemes in Case 1

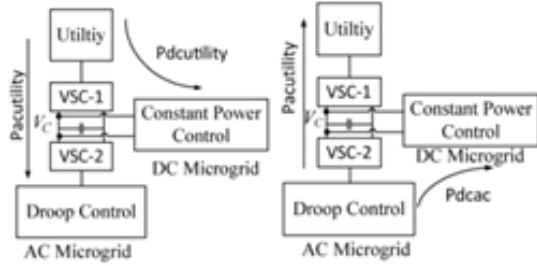

Fig. 8 Power flow schemes in Case 2

Case 2: In this case, extra power requirement in the AC micro grid is supplied by the utility while the micro sources in the AC micro grid operate on fixed power output. The DC micro grid micro sources may operate with fixed power or droop control. In the simulation actually we are controlling the amplitude of the VSC-1 input in order to reduce the voltage level at utility side so that the power flow from micro grid to utility can be explained.

VII. SIMULATION RESULTS

The simulation consist of a utility grid ,DC micro grid and an AC micro grid .The output of the hybrid grid is taken from the back to back converter end of both AC and DC micro grid.

The DC micro grid uses Photo Voltaic Module and Fuel Cell stack as Distribution Generation Units. The each of its output is boosted and is linked with utility via back to back converter.

While in AC micro grid for the simplicity in simulation the distributed generators are provided by ideal DC source and the entire module is incorporated in the VSC blocks of AC micro grid.

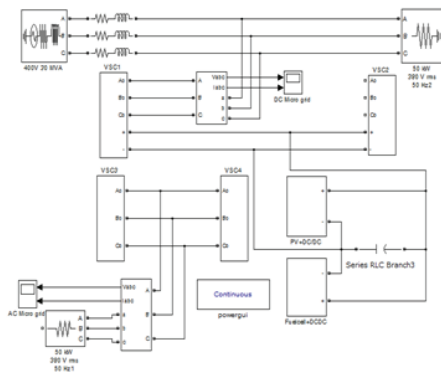

Fig. 9 Simulation of hybrid micro grid

Mode 1 operation

In this case a fixed power is supplied from the utility to the AC micro grid (or vice versa) and voltage control is achieved for the DC micro grid. As the power from the AC grid is controlled in this case, it is more suitable for a contractual scenario with the AC micro grid.

For simulation of this mode we have to show that there exist current flow from utility to AC micro grid so the back to back converter and the VSCs of the AC grid are connected with a three phase voltage current measurement block and the current in that part of the model is measured hence the flow from utility to micro grid.

Mode 2 Operation

In this case, extra power requirement in the AC micro grid is supplied by the utility while the micro sources in the AC micro grid operate on fixed power output. The DC micro grid micro sources may operate with fixed power or droop control.

In the simulation actually we are controlling the amplitude of the VSC-1 input in order to reduce the voltage level at utility side so that the power flow from micro grid to utility can be explained.

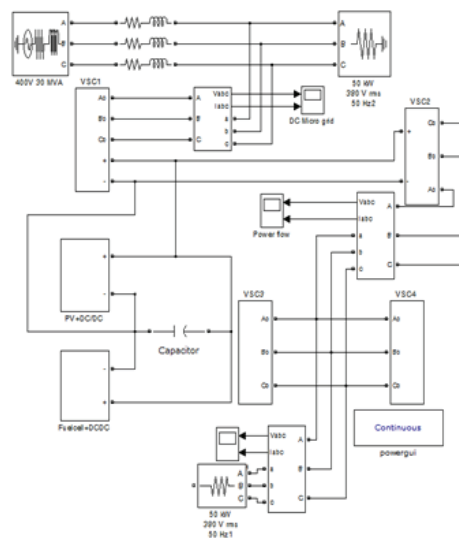

Fig. 10 Simulation of Mode 1 operation

PV Module at DC micro grid

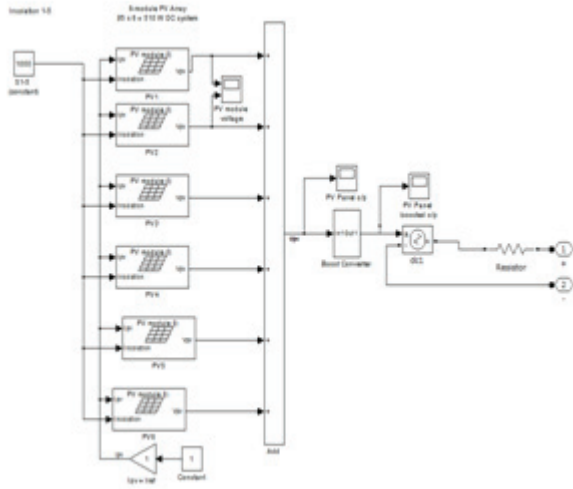

Fig. 11 Simulation of PV Module at DC micro grid

In this simulation we have three outputs one output of individual photo voltaic(PV) module and second one the combined output of the photo voltaic(PV) panels and the third one is the boosted output of the photo voltaic(PV) panels which is fed to the DC micro grid via a current limiter. Fuel stack at DC micro grid.

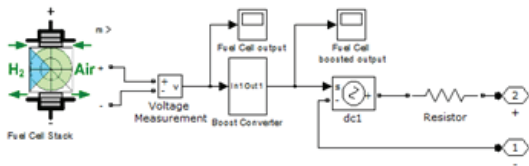

Fig. 12 Simulation of Fuel stack at DC micro grid

In this simulation a fuel cell stack is used as distributed generator and have two outputs one actual fuel cell output and the other the boosted output of fuel cell stack which is fed to the DC micro grid via a current limiter.

SIMULATED OUTPUTS

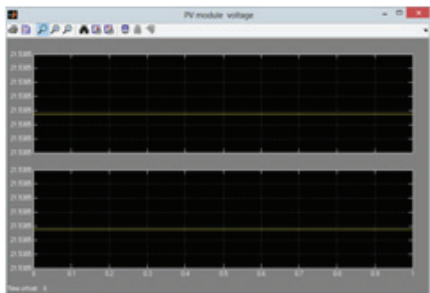

Fig. 13 Simulated output of Photo voltaic module

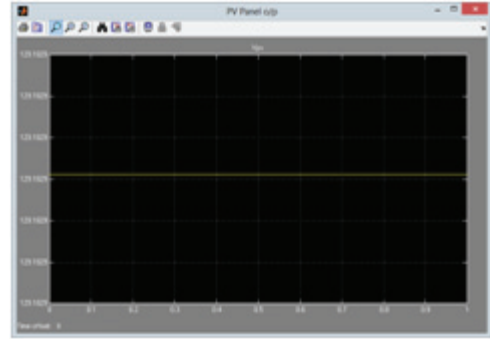

Fig. 14 Simulated output of Photo voltaic panel combi

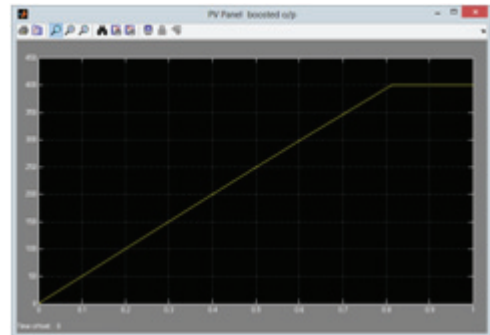

Fig. 15 Simulated boosted output of Photo voltaic panel

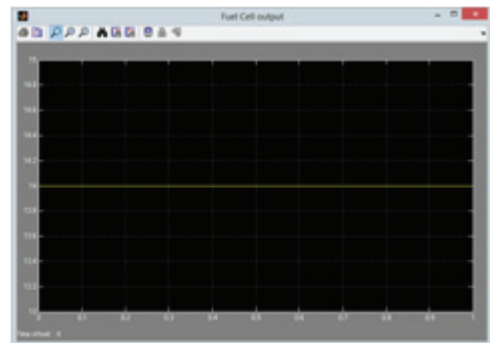

Fig. 16 Simulated output of Fuel cell stack

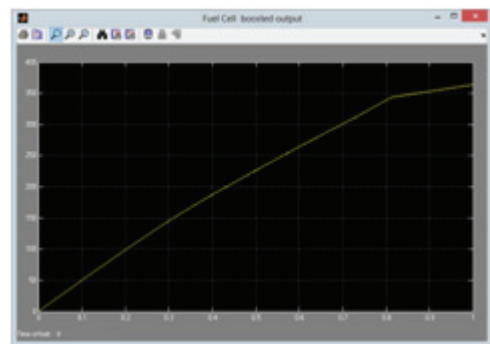

Fig. 17 Simulated boosted output of Fuel cell stack

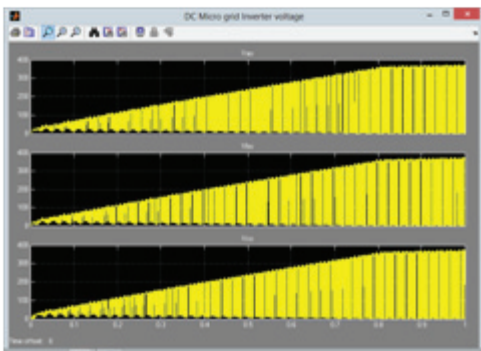

Fig. 18 Simulated output of VSC at DC end

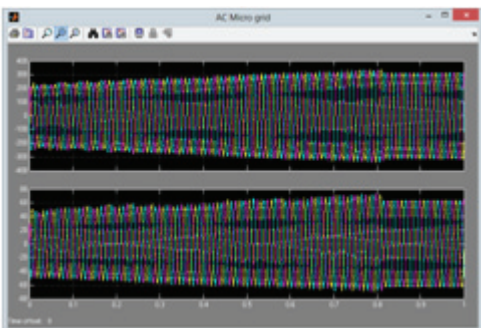

Fig. 19 Simulated output of AC micro grid

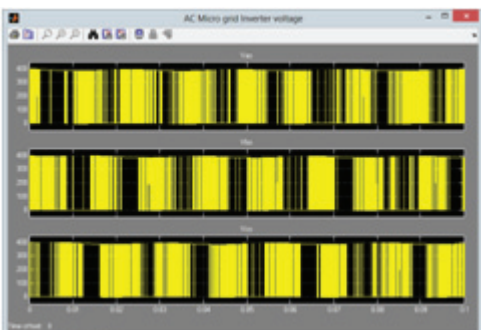

Fig. 20 Simulated output of VSC at AC end

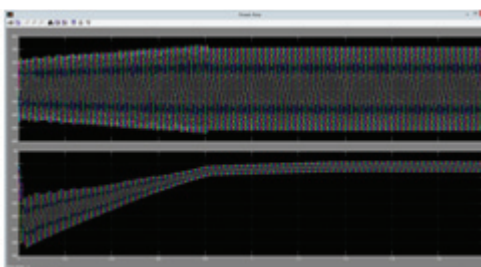

Fig. 21 Simulated output of power flow from utility to AC micro grid

TABLE I ADVANTAGE OF PROPOSED MICROGRID STRUCTURE

Property	Proposed Structure	Existing Structure
Use of AC and DC system	Yes	Yes
Isolation of AC DC system	Yes	Yes
Utility Connection	Through common DC bus	Only Possible at AC bus
Power Management	Different mode possible centralized control	Back to back link based control
Fault Isolation	Hierarchical	Individual
Utility Power Flow Contract	Separate for AC and DC micro grid	Harder to implement
Islanding Control	One PCC for one Micro grid	Harder to implement
Different Grounding System	Possible	Harder to implement
Separate Black Start	Possible	Harder to implement

VIII. CONCLUSION

The necessity of an AC or DC micro grid is governed by available micro sources and connected loads. A hybrid structure can ensure a sustainable configuration blending both the forms. A hybrid micro grid structure for grid connected micro grid through B2B is proposed. The proposed control scheme can provide an isolated, reliable system connection with improved power flow management. Various control modes of the micro sources in the micro grids are investigated to validate system sustainability in different power flow and system contingencies. A stable system ensures the efficacy of the proposed scheme and control methods.

For the future work the H bridge converter in VSC is replaced by a multilevel inverter for reducing the number of switching operation, better approximation of sin wave and improved efficiency.

REFERENCES

- [1] P. Loh, D. Li, Y. Chai, and F. Blaabjerg, "Autonomous operation of hybrid microgrid with AC and DC sub-grids," *IEEE Trans. Power Electron.*, vol. 28, no. 5, pp. 2214–2223, May 2013.
- [2] L. Xiong, W. Peng, and P. Loh, "A hybrid AC/DC micro-grid," in *Proc. IPEC 2010 Conf.*, Oct. 27–29, 2010, pp. 746–751.
- [3] L. Xiong, W. Peng, and P. Loh, "A hybrid AC/DC microgrid and its co-ordination control," *IEEE Trans. Smart Grid*, vol. 2, no. 2, pp. 278–286, Jun.
- [4] A. A. A. Radwan and Y. A. Mohamed, "Assessment and mitigation of interaction dynamics in hybrid AC/DC distribution generation systems," *IEEE Trans. Smart Grid*, vol. 3, no. 3, pp. 1382–1393, Sep. 2012.
- [5] C. Tsung-Po Chen, "Zero-sequence circulating current reduction method for parallel HEPWM inverters between AC bus and DC bus," *IEEE Trans. Ind. Electron.*, vol. 59, no. 1, pp. 290–300, Jan. 2012.
- [6] M. Akbari, M. A. Golkar, and S. M. M. Tafreshi, "Voltage control of a hybrid ac/dc microgrid in grid-connected operation mode," in *Proc. IEEE PES Innovative Smart Grid Technologies India*, Dec. 1–3, 2011, pp. 358–362.
- [7] M. Akbari, M. A. Golkar, and S. M. M. Tafreshi, "A PSO solution for improved voltage stability of a hybrid ac-dc microgrid," in *Proc. IEEE PES Innovative Smart Grid Technologies (ISGT) India*, Dec. 1–3, 2011, pp. 352–357.
- [8] D. Bo, L. Yongdong, Z. Zhixue, and X. Lie, "Control strategies of microgrid with hybrid DC and AC buses," in *Proc. 14th Eur. Conf. Power Electronics and Applications (EPE 2011)*, 2011, pp. 1–8.
- [9] J. Zhenhua and Y. Xunwei, "Hybrid DC- and AC-linked microgrids: Towards integration of distributed energy resources," in *Proc. Energy 2030 Conf.*, Nov. 17–18, 2008, pp. 1–8.
- [10] J. Zhenhua and Y. Xunwei, "Power electronics interfaces for hybrid DC and AC-linked microgrids," in *Proc. 6th IEEE Int. Conf. Power Electronics and Motion Control*, May 17–20, 2009, pp. 730–736.
- [11] D. Bo, Y. Li, and Z. Zheng, "Energy management of hybrid DC and AC bus linked microgrid," in *Proc. 2nd IEEE Int. Conf. Power Electronics for Distributed Generation Systems (PEDG)*, Jun. 16–18, 2010, pp. 713–716.
- [12] M. N. Ambia, A. Al-Durra, and S. M. Mueeen, "Centralized power control strategy for AC-DC hybrid micro-grid system using multi-converter scheme," in *Proc. 37th Annu. IEEE Industrial Electronics Society Conf. (IECON)*, Nov. 7–10, 2011, pp. 843–848.
- [13] A. Chaouachi, R. Kamel, R. Andoulsi, and K. Nagasaka, "Multi-objective intelligent energy management for a microgrid," *IEEE Trans. Ind. Electron.*, vol. 60, no. 4, pp. 1688–1699, Apr. 2013.
- [14] A. Ghazanfari, M. Hamzeh, H. Mokhtari, and H. Karimi, "Active power management of multihybrid fuel cell/supercapacitor power conversion system in a medium voltage microgrid," *IEEE Trans. Smart Grid*, vol. 3, no. 4, pp. 1903–1910, Dec. 2012.
- [15] K. T. Tan, X. Y. Peng, P. L. So, Y. C. Chu, and M. Z. Q. Chen, "Centralized control for parallel operation of distributed generation inverters in microgrids," *IEEE Trans. Smart Grid*, vol. 3, no. 4, pp. 1977–1987, Dec. 2012.
- [16] P. Siano, C. Cecati, H. Yu, and J. Kolbusz, "Real time operation of smart grids via FCN networks and optimal power flow," *IEEE Trans. Ind. Inform.*, vol. 8, no. 4, pp. 944–952, Nov. 2012.
- [17] K. Nunna and S. Doolla, "Multi agent based distributed energy resource management for intelligent microgrids," *IEEE Trans. Ind. Electron.*, vol. 60, no. 4, pp. 1678–1687, Apr. 2012.
- [18] A. H. Etemadi, E. J. Davison, and R. Iravani, "A decentralized robust control strategy for multi-DER Microgrids—Part I: Fundamental concepts," *IEEE Trans. Power Del.*, vol. 27, no. 4, pp. 1843–1853, Oct. 2012.
- [19] R. Majumder, A. Ghosh, G. Ledwich, and F. Zare, "Power management and power flow control with back-to-back converters in a utility connected microgrid," *IEEE Trans. Power Syst.*, vol. 25, no. 2, pp. 821–834, May 2010.
- [20] F. Shahnia, R. Majumder, A. Ghosh, G. Ledwich, and F. Zare, "Operation and control of a hybrid microgrid containing unbalanced and nonlinear loads," *Elect. Power Syst. Res.*, vol. 80, no. 8, pp. 954–965, Sep. 2010.
- [21] P. Thounthong, B. Davat, S. Rael, and P. Sethakul, "Fuel cell high-power applications," *IEEE Ind. Electron. Mag.*, vol. 3, no. 1, pp. 32–46, Mar. 2009.