

# Passive Energy Recovery Snubber Based DC-DC Boost Converter

P. Radika

Professor, Department of EEE, Adhiparasakthi Engineering College, Melmaruvathur, India  
E-mail: radikasenthil@gmail.com

**Abstract** – A dc-dc boost converter capable of delivering a high output voltage and efficiency is proposed. The proposed converter uses passive energy recovery snubber. The snubber is used to reduce the turn-off loss of the main switch and the snubber stored energy is effectively recovered into the output side. The simulation and experimental results of the proposed converter is compared with a conventional boost converter at low voltage conditions. The results obtained shows that the proposed model has high output voltage, efficiency and low switching loss.

**Keywords** – snubber, passive regenerative snubber, turn-off loss, boost converter, switching loss, energy recovery snubber, snubber capacitor, turn-off snubber

## I. INTRODUCTION

In recent times, dc-dc boost converters with high voltage gain and efficiency are required in several applications like the front-end converters for a battery source, Uninterruptible Power Supply (UPS), renewable energy systems such as fuel cell system, photovoltaic solar and wind systems. The main advantages of using conventional boost converter in these applications are simple structure, reduced component count and better efficiency. However, in the conventional boost converter, high voltage gain and high efficiency are hard to achieve, due to the loss associated with the boost inductor, filter capacitor, main switch and output diode [1]. As a result, a general boost converter would not be acceptable for high step-up applications [2]. To overcome these limitations, various types of soft-switching boost converters utilizing the voltage conversion ability of a transformer, a coupled inductor and a resonant voltage doubler to obtain high voltage gain and efficiency have been built for high power applications [3]. Soft-switching boost converter topologies with passive and active snubbers have also been developed for high power applications [4].

### A. Snubber network and its necessity

Power dissipation in a semiconductor switching device is generic in nature. During the turn-on and turn-off switching transition intervals, a large instantaneous power dissipation occurs in the device [5], [6]. As the switching frequency increases, these transitions occur more often and the average switching power loss in the device increases. However, high switching frequencies are desirable because of the reduced size of power converters. Then, it is necessary to develop soft switching techniques to aid switching commutations. Also, snubber circuits are used to modify the switching waveforms to reduce the switching power loss. Thus, snubbers are the circuits which are placed across the semiconductor devices to reduce the switching stress on semiconductor devices and to reduce the switching losses

during the switching transition interval and to improve its performance. During turn-on, a series inductance (Turn-on snubber/Series snubber) is used to limit the rate of rise of current ( $di/dt$ ) through the switch. And, a parallel capacitor (Turn-off snubber/Shunt snubber) is used to limit the rate of rise of voltage ( $dv/dt$ ) across the switch during the turn-off transition interval. And, it is also possible to obtain soft-switching by means of snubbers [7], [8].

### B. Snubber size and energy recovery snubbers

According to definition of McMurray a snubber may be small, normal and large, as shown in Fig. 1. In a small shunt snubber the voltage reaches quickly to the rated input voltage level. Hence, it is not sufficient for turn-off protection. A normal shunt snubber provides sufficient turn-off protection. Whereas, in a large shunt snubber the voltage rises slowly to reach the rated input voltage level, thus, providing good turn-off protection. Similarly, the series snubbers are defined in terms of current rise at turn-on condition [9], [10].

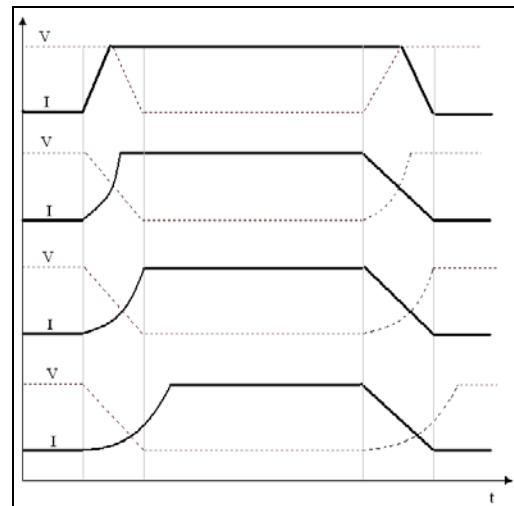

Fig. 1 Voltage and current waveforms of a switch with different sizes of snubber (a) No snubber (b) Small snubber (c) Normal snubber (d) Large snubber

During snubbing action energy is stored in the inductive/capacitive components. This stored energy must be removed after each switching transition for repetitive snubbing action. One of the simple methods is discharge the stored energy into a resistor which results in dissipative snubbers. Alternatively, regenerative/ energy recovery snubbers can be used to transfer this stored energy into the output or input of the converters so that it is not wasted. This may be passive or active one [11], [12] and [4].

Fig. 2 compares the results of a conventional boost converter with and without snubber protection. This clearly shows that the stress is reduced with snubber and an increase in snubber capacitance causes considerable reduction in stress also. In general, with increase in snubber inductance/capacitance, the power dissipation in the switching device/stress decreases (improved snubbing) and the stored energy increases [13], [7]. Dissipative snubbers (RLD/RCD) are those which dissipate the snubber energy they absorb in a resistor. Hence, the loss in the discharge resistor (snubber loss) which equals the energy stored in the snubber inductance/capacitance. This proportionally increases with an increase in size of the snubber element and switching frequency. This leads to reduction in efficiency of the system. Thus an improvement in efficiency is obtained by means of energy regenerative snubbers.

## II. PROPOSED PASSIVE REGENERATIVE SNUBBER

Fig. 3 shows the proposed passive boost converter. It differs from a conventional PWM boost converter by adding a passive regenerative snubber network which consists of snubber capacitors ( $C_{s1}$ ,  $C_{s2}$ ), snubber diodes ( $D_{s1}$ ,  $D_{s2}$ ) and the energy recovery circuit components of resonant inductors ( $L_{r1}$ ,  $L_{r2}$ ) and diodes ( $D_{r1}$ ,  $D_{r2}$ ). The basic principle is that the two identical snubber capacitors are charged in parallel and discharged in series at off - on transition of the main switch, thus recovering the stored energy [14]. The proposed one has two modes of operation as shown in Fig. 4.

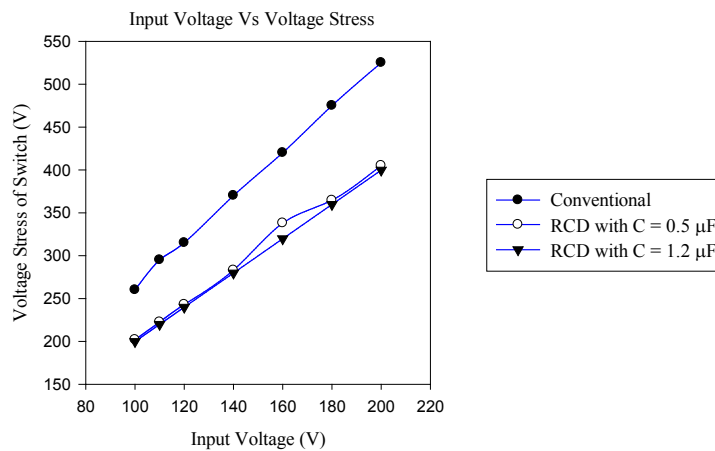

Fig. 2 Input voltage Vs Stress of conventional converter without snubber and with RCD dissipative snubber

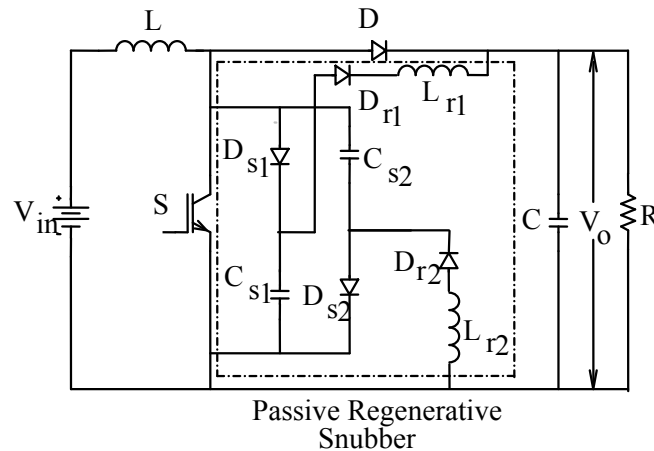

Fig. 3 Proposed boost converter with passive regenerative snubber

### A. Mode 1 operation

Assuming that, initially, the voltage across the snubber capacitors  $C_{s1} = C_{s2} = C_s$  is zero. In Fig. 4(a), the main switch S turns-off at zero voltage condition. The inductor current  $I_L$  is transferred to the snubber capacitors charging them equally

up to the output voltage  $V_o$  ( $V_o = V_{in} + V_L$ ). The diode D conducts exactly in the same manner as diode D of conventional boost converter. During this mode, the voltage across the each snubber capacitor  $V_{C_s}$  is given as

$$V_{C_s}(t) = \frac{I_L t}{2C_s} \quad (1)$$

Based on the design of turn-off snubber, if the snubber capacitor voltage  $V_{C_s} = V_o$  is obtained during this interval, the snubber capacitor  $C_s$  is given as follows

$$C_s = \frac{I_L t}{2V_o} \quad (2)$$

In general, this shunt snubber is named as normal snubber  $C_n$ .

### B.Mode 2 operation

At the turn-on of the switch as shown in Fig. 4(b), the superimposed capacitor voltage  $2V_o$  discharges resonantly into the output side. The switch carries both the main current  $I_L$  and the capacitor discharging current  $I_c$ . At the end of this mode of operation, the voltage across the capacitors becomes zero. Therefore, at ZVS condition the switch is turned-off again. If the voltage across each snubber capacitor, at the end of the charging condition, is  $V_{C_{so}}$ , then, the Equations (3) and (4) give the capacitor current  $I_c$  and voltage  $V_{C_s}$  respectively during the discharging period.

$$I_c(t) = \frac{2V_{C_{so}} - V_o}{2Z} \sin \omega t \quad (3)$$

$$V_{C_s}(t) = \frac{2V_{C_{so}} \cos \omega t + V_o(1 - \cos \omega t)}{2} \quad (4)$$

where,  $C_{s1} = C_{s2} = C_s$ ,  $L_{r1} = L_{r2} = L_r$  and

$$\text{Resonant impedance } Z = \sqrt{\frac{L_r}{C_s}} \quad (5)$$

$$\text{Resonant frequency } \omega = \frac{1}{\sqrt{L_r C_s}} \quad (6)$$

From these equations, the following analysis is taken. At  $\omega t = \pi$ ,

1. If  $V_{C_{so}} = V_o$ ,  $V_c$  reaches zero at the end of the oscillations; then, all of the capacitive energy is recovered into the output.
2. If  $V_{C_{so}} > V_o$ , all the energy is recovered and  $V_c$  reaches zero before  $\omega t = \pi$ .
3. If  $V_{C_{so}} < V_o$ , a part of the capacitor voltage,  $2(V_o - V_{C_{so}})$ , remains unrecovered.
4. The recovery process can also be analysed based on the size of the snubber capacitance as shown in Figure 4.
  - a. If  $C_s < C_n$  is small snubber, it allows the capacitor voltage to reach zero before the discharging current reaches zero and this provides complete energy recovery as shown in Fig. 5(a).
  - b. If  $C_s = C_n$  is normal snubber, it allows the snubber capacitor voltage and its discharging current to reach zero at the same time, thus, recovering all the snubber stored energy as shown in Fig. 5(b).
  - c. If  $C_s > C_n$  is large snubber, it provides non-zero capacitor voltage. Thus partial energy recovery takes place as shown in Fig. 5(c).

### III. SIMULATION ANALYSIS AND DISCUSSIONS

#### A. Design of circuit components

The reference circuit parameters are given in Table 1. Table 2 shows the designed parameters based on the basic operation of the conventional boost converter.

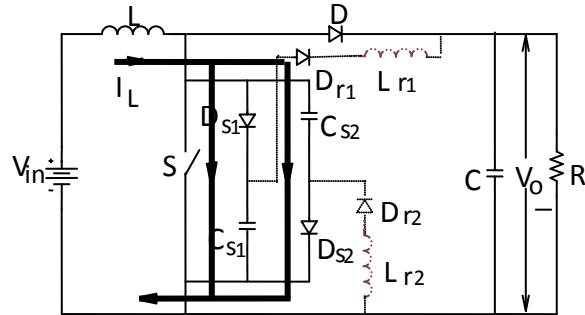

(a)

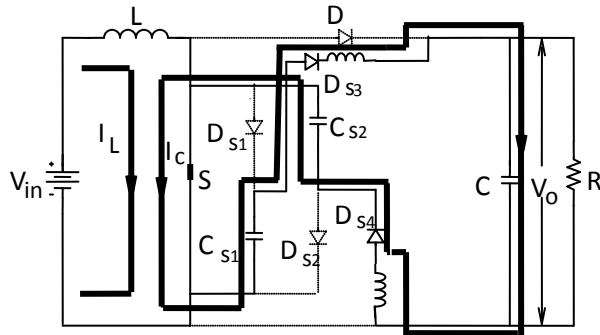

(b)

Fig. 4 Modes of operation of a proposed converter  
 (a) Mode 1 operation: Snubber capacitors to charge when main switch turns off  
 (b) Mode 2 operation: Discharging the snubber voltages into the output side when main switch turns on

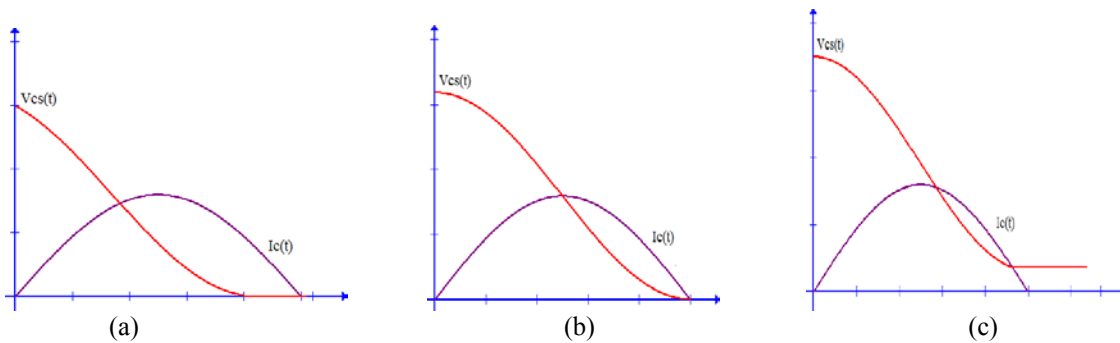

Fig. 5 Behavior of  $V_c$  and  $I_c$  for different snubbers (a) Small snubber (b) Normal snubber (c) Large snubber

**B. Simulation results**

The simulation results are obtained using MATLAB/SIMULINK/ PLECS.

TABLE 1. REFERENCE PARAMETERS

Parameter	Value
Input voltage, $V_{in}$	15 V
Duty cycle, $d$	0.5
Switching frequency, $f_s$	25 kHz
Load resistance, $R$	500 $\Omega$
Input current ripple, $\Delta I_{in}$	2.5 %
Output voltage ripple, $\Delta V_o$	0.0125

TABLE 2. CALCULATED PARAMETERS

Parameter	Value
Output voltage, $V_o$	30 V
Input boost inductance, $L$	100 mH
Output filter capacitor, $C$	100 $\mu F$

**1. Case I: Input voltage of  $V_{in} = 15$  V with  $L = 100$  mH**

The simulation results of conventional boost converter under this condition are shown in Table 3.

TABLE 3. RESULTS OF CONVENTIONAL BOOST CONVERTER

$V_{in}$ (V)	$V_o$ (V)	Theoretical $V_o$ (V)	Efficiency (%)
15	29.17	30	78.98

In regenerative snubber, the increase in snubber size causes proportional increase in stored energy in the snubber element and also the amount of energy fed back to the input/output side. This improves the system efficiency. Therefore, for a proposed converter, the selection of the size of the snubber capacitance is an important factor to obtain the better performance. Since, the main switch turn-off loss can only be reduced by snubber capacitor, it is necessary to select a snubber capacitor so that further increments of snubber capacitance will not significantly further reduce the turn-off loss. Using the same reference parameters, the proposed converter is simulated for different values of

snubber capacitance ( $C_s = \frac{I_L t}{2V_o}$ ). The obtained output voltage and efficiency are plotted in Fig. 6 and the summary is given in Table 4.

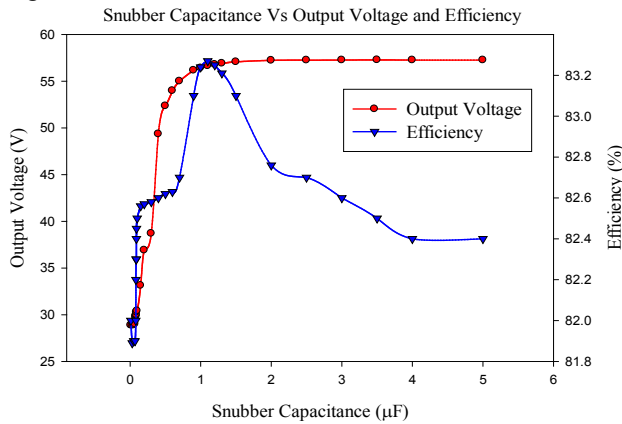

Fig.6 Snubber capacitance Vs output voltage and efficiency of a proposed converter

TABLE 4. RESULTS OF PROPOSED CONVERTER

Snubber capacitance ( $\mu F$ )	Output voltage (V)	Efficiency (%)
Group I 0.01 - 0.088	28.88 - 29.95 Same as conventional boost converter	82.0 - 82.3 Improvement in efficiency
Group II 0.089 - 0.12 and 0.13 - 0.32	30.01 - 31.0 and 32.5 - 40.0 Higher than conventional	82.4 - 82.5 and 82.52 - 82.58 Improvement in efficiency
Group III 0.33 - 0.4 and 0.5 - 5	43.8 - 49.5 and 52.34 - 57.26 Almost double the conventional	82.58 - 82.6 and 82.4 - 83.27 Improvement in efficiency

Based on the results obtained, the snubber capacitors can be classified as three groups:

- Group I as small snubber
- Group II as normal snubber
- Group III as large snubber

Group I (0.01 - 0.088  $\mu F$ ) is taken as small snubber which provides complete energy recovery. Group II is taken as normal snubber. The range (0.089 - 0.12  $\mu F$ ) is an ideal normal snubber and provides complete energy recovery. But the range (0.13 - 0.32  $\mu F$ ) provides partial recovery only. Group III is large snubber which provides partial energy recovery; and, here, voltage doubling also exists. Compared with the conventional converter, Group I provide the output which is almost the same as conventional one and Group II is with slight increase of output. Group III has almost twice the output voltage. Whereas, all the three groups have an improvement in efficiency.

For different input voltage (5 - 25 V) conditions the results obtained are as follows: The small snubber provides an increase in output voltage in the range of 0.72 - 2 % with an increase in efficiency of 1.39 - 4.2 %. The normal snubber provides better result than the small snubber. It has an increase in output voltage in the range of 1.08 - 2.38 % with an increase in efficiency of 1.39 - 4.3 %. Since the large snubber acts as a voltage doubler, the increase in output voltage is in the range of 46.53 - 48 % with an increase in efficiency of 2.5 - 6 %.

**2. Case II: Input voltage of  $V_{in} = 15\text{ V}$  with  $L = 1\text{ mH}$**

Using the same parameters of case I, and current ripple of 1A is taken. This gives  $L = 0.3\text{ mH}$ . The conventional boost converter is simulated for different values of  $L$  around this. With  $L = 1\text{ mH}$  and the same parameters of case I, the results obtained are shown in Table 5. Compared with case I, an increase in efficiency with the same output voltage is obtained under this condition due to low boost inductance. The proposed converter is simulated with the same boost inductance value. Compared with case I an increase in efficiency with a small reduction in the output voltage is obtained as shown in Fig. 7.

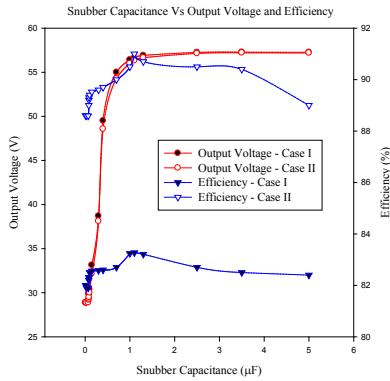

Fig. 7 Snubber capacitance Vs output voltage and efficiency of a proposed converter with case I and case II parameters

TABLE 7. SPECIFICATIONS OF COMPONENTS

Component	Value
IGBT	IRG4BC30S
Diode	1N5817
Input voltage	15 V
Input inductance	1 mH
Snubber capacitance	0.01 - 3.8 $\mu\text{F}$
Output filter capacitance	100 $\mu\text{F}$
Load resistance	500 $\Omega$

TABLE 8. RESULTS OF CONVENTIONAL BOOST CONVERTER

Input voltage (V)	Output voltage (V)	Efficiency (%)
15	30.14	83.48

Table 6 shows the turn-off energy loss of the converters using MATLAB/PLECS. The results obtained shows that the turn-off loss is reduced in the proposed converter. With increase in snubber capacitance the loss is reduced. With  $C_s = 1.1\mu\text{F}$  (Large snubber), the obtained loss is shown.

TABLE 6. TURN-OFF ENERGY LOSS OF THE CONVERTERS

Converter	Turn-off energy loss ( $\mu\text{J}$ ) at $V_{in} = 15\text{ V}$
Conventional	51.0
Proposed	11.6

**IV. EXPERIMENTAL RESULTS**

A laboratory model of the converters is developed with the following specifications (Table 7). The observation of the conventional converter is shown in Table 8. The results of the proposed converter are shown in Fig. 8.

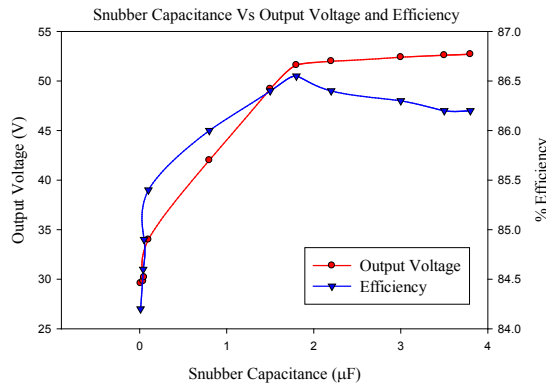

Fig. 8 Snubber capacitance Vs output voltage of a proposed converter

Based on the results obtained the snubber capacitors can be taken as,

- Small snubbers : 0.01  $\mu\text{F}$  and 0.04  $\mu\text{F}$
- Normal snubbers : 0.05  $\mu\text{F}$  (Ideal) and 0.1  $\mu\text{F}$
- Large snubbers : 0.8  $\mu\text{F}$ , 1.5  $\mu\text{F}$ , 1.8  $\mu\text{F}$ , 2.2  $\mu\text{F}$ , 3  $\mu\text{F}$ , 3.5  $\mu\text{F}$ , 3.8  $\mu\text{F}$

Compared with the conventional converter the changes are described as follows,

- Small snubbers : Decrease in output voltage with an increase in efficiency
- Normal snubbers : Increase in output voltage with an increase in efficiency

- Large snubbers : Increase in output voltage with an increase in efficiency

The large snubber capacitance of 1.8  $\mu\text{F}$  provides the maximum efficiency of 86.55 %.

Fig. 9 and Table 9 shows the comparison of simulation result with the experimental result of a proposed converter with  $V_{in} = 15 \text{ V}$ . The simulated output voltage for higher range of snubber capacitance and the simulated efficiency for all range of snubber capacitance show a close conformity with the experimental result.

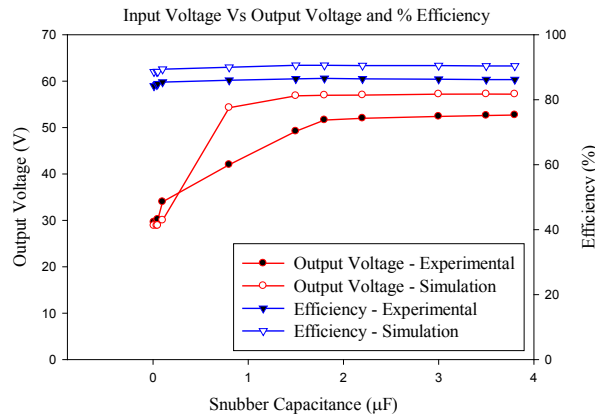

Fig. 9 Comparison of simulation and experimental results of a proposed converter

TABLE 9. RESULTS OF CONVENTIONAL AND PROPOSED CONVERTERS

Conventional converter				
Input voltage (V)	Snubber capacitance ( $\mu\text{F}$ )	Output voltage (V)	Efficiency (%)	Mode
15	--	29.16	86.52	Simulation
15	--	30.14	83.48	Experimental
Proposed converter				
15	0.01 - 5	28.86 - 57.2	88.6 - 90.7	Simulation
15	0.01 - 4	29.6 - 52.7	84.2 - 86.55	Experimental

### V. CONCLUSION

In this paper a dc-dc boost converter with passive energy recovery snubber to feed back the snubber stored energy into the output side is proposed. The output voltage and efficiency are analyzed for different values of snubber capacitance at low input voltage conditions. The results are compared with the conventional model. The turn-off switching loss is simulated for both the converters and the reduction in the loss of the proposed model is shown. A prototype model of the converters is developed. The improvement in output voltage and efficiency of the proposed converter with  $C_s = 1.8 \mu\text{F}$  are 41.6 % and 3.55 % respectively which are more than the conventional.

From the analysis, it has been found that the proposed converter has better output voltage and efficiency than that of the conventional converter.

### REFERENCES

- [1] Changchien S, Liang T, Chen J & Yang L, "Novel High Step up DC-DC Converter for Fuel Cell Energy Conversion System," IEEE Transactions on Industrial Electronics, vol. 57, no. 6, 2010, pp. 2007-2017.
- [2] Park K, Moon G & Youn M, "Nonisolated High Step-up Boost Converter Integrated With Sepic Converter," IEEE Transactions on Power Electronics, vol. 25, no. 9, 2010, pp. 2266-2275.
- [3] Park J, Choi W & Kwon B, "A Step-Up DC-DC Converter with a Resonant Voltage Doubler," IEEE Transactions on Industrial Electronics, vol. 54, no. 6, 2007, pp. 3267- 3275.

- [4] Wu T F, Chang Y D, Chang C H, Lee H X, Lee K Y & Yang J G, "A 5 kW Boost Converter With Various Passive/Active Snubbers for Reducing Component Stress and Achieving High Efficiency," IEEE Proceedings on Power Electronics and Drive Systems: PEDS 2007, Taipei, 2009.
- [5] Mohan, Undeland & Robbins, "Power Electronics Converters, Applications and Design," (Wiley), 2001.
- [6] Muhammad H Rashid, "Power Electronics Hand Book," (Academic Press), 2001.
- [7] Charl G Steyn & Jacobus D Van Wyk, "Optimum Nonlinear Turn-Off Snubbers: Design and Applications," IEEE Transactions on Industry Applications, vol. 25, no. 2, 1989, pp. 298-304.
- [8] Marco Antonio Mora Barajas, Mariano Fernández Naval & Pedro Bañuelos Sánchez, "Stress Reduction Non-Dissipative Snubber Circuit for a PFC Converter," IEEE CIEP, 2010.
- [9] Sen P C, "Modern Power Electronics," (Wiley), 2000.
- [10] William MuMurray, "Selection of Snubbers and Clamps to Optimize the Design of Transistor Switching Converters," IEEE Transactions on Industry Applications, vol. IA-16, no. 4, 1980, pp. 513-523.
- [11] Yuanyuan Yang & Xu Weisheng, "A Simplified Lossless Passive Soft-Switching Snubber for PWM half-bridge Inverters," IEEE International Conference on Intelligent Computation Technology and Automation, Changsha, Hunan, 2009.
- [12] Jennifer Bauman & Mehrdad Kazerani, "A Novel Capacitor-Switched Regenerative Snubber for DC/DC Boost Converters," IEEE Transactions on Industrial Electronics, vol. 58, no. 2, 2011, pp. 514-523.
- [13] Steyn C G, "Optimum Size of Dissipative Nonlinear Turn-off Snubber," IEE Electric Power Applications, vol. 135, no. 4, 1988, pp. 165-171.
- [14] Kenichiro Fujiwara & Hiroshi Nomura, "A Novel Lossless Passive Snubber For Soft-switching Boost-Type Converters," IEEE Transactions on Power Electronics, vol. 4, no. 6, 1999, pp. 1065-1069.