

# Load Frequency Control of Single Area System Using Ziegler-Nichols and Genetic Algorithm

P. Praveena<sup>1</sup>, H. S. Shubhanka<sup>2</sup>, V. Neha<sup>3</sup>, P. Prasath<sup>4</sup> and G. S. Veda<sup>5</sup>

<sup>1,2,3,4&5</sup>Department of Electrical and Electronics Engineering,  
 MVJ College of Engineering, Bangalore, Karnataka, India  
 E-Mail: [puvada.praveena@mvjce.edu.in](mailto:puvada.praveena@mvjce.edu.in), [nagashree.neha@gmail.com](mailto:nagashree.neha@gmail.com)

(Received 11 April 2019; Revised 30 April 2019; Accepted 22 May 2019; Available online 28 May 2019)

**Abstract** - In this paper, determining the optimal proportional-integral-derivative (PID) controller gains of load frequency control (LFC) system using Ziegler-Nichols (ZN) and Genetic algorithm (GA) is presented. The conventional tuning of PID is difficult as the system and the load parameters change constantly. It is for this reason tuning strategies has been applied. Comparative studies of both the techniques are presented. The simulation has been conducted in MATLAB Simulink package for single area power system.

**Keywords:** Load Frequency Control (LFC), PID Controller, Genetic Algorithm (GA) and Ziegler-Nichols (ZN)

## I. INTRODUCTION

Maintaining the power system frequency constant and near the nominal value is of paramount importance from the operation point of view of modern power system with industrial and commercial loads. Thus, Load Frequency Control (LFC) is essential for supplying sufficient, reliable and good quality power [1]. The aim of LFC is to maintain zero steady state error for frequency deviation [2]. In this study, a single area power system is taken into consideration [3]. The load frequency control of this system is done by incorporating a proportional integral derivative (PID) controller, which is optimized using Ziegler-Nichols tuning technique (ZN) and Genetic Algorithm (GA). A single area system basically consists of a governor, a turbine and a generator with feedback of constant regulation. This system also includes step load change input to the generator.

## II. ZIEGLER NICHOLS

The Ziegler Nichols tuning technique is a heuristic approach of tuning a PID controller [5]. It was proposed by John .G. Ziegler and Nathaniel. B. Nichols in 1942. The advantage of ZN-PID controller tuning is that it can carried out for higher order systems also.Z-N PID controller is controlling the plant or system by continuously monitoring plant output which is known as process value with desired process value known as set point of the system. In conventional controlling method, the transfer function of the plant is obtained in order to find out various parameters and the PID gains of the system [4]. But in this method, it is no necessary to derive the transfer function of the system.

*A. Ziegler-Nichols Tuning Rule:* Ziegler-Nichols tuning technique provides a practical approach to tune a PID

controller. According to the rule, PID controller is tuned by firstly setting the integral and derivative parameters to zero and by adjusting the proportional gain to put the control system in continuous oscillations.

1. With P as the only closed loop control, increase the magnitude of the proportional gain until the closed loop is in a continuous oscillation. For slightly larger value of controller gain, the closed loop system is unstable while for slightly lower value the system is stable.
2. The value of controller proportional gain that causes the continuous oscillation is called the critical gain or ultimate gain ( $K_u$ ). The peak to peak period is called the critical period or ultimate period ( $T_u$ ).
3.  $K_u$  and  $T_u$  are used to set the PID gains depending on the type of controller used.

## B. Ziegler-Nichols Tuning Table

TABLE I ZIEGLER NICHOLS TUNING TABLE

Controller	Kp	Ki	Kd
P	0.5 $K_u$	-	-
PI	0.45 $K_u$	0.54 $K_u/T_u$	-
PID	0.6 $K_u$	1.2 $K_u/T_u$	0.6 $K_u T_u/8$

## III. SIMULINK MODEL

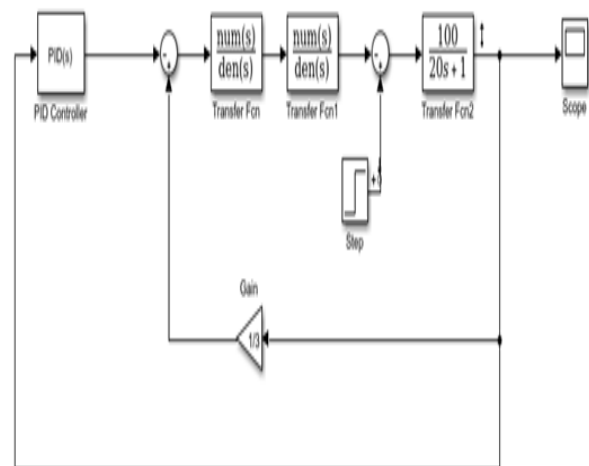

Fig. 1 Single area closed loop PID controller system

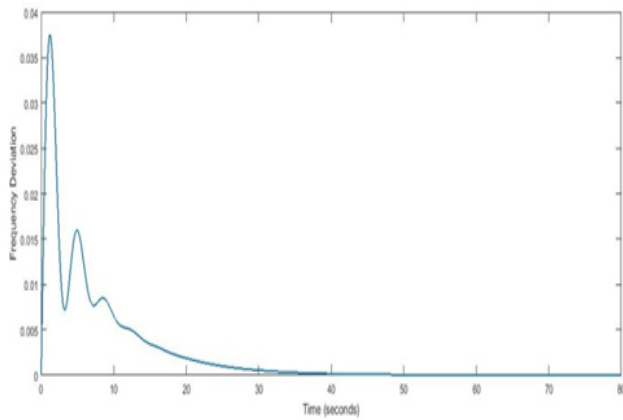

Fig. 2 Output waveform of ZN-PID controller

#### IV. SIMULATION STUDY

The Ziegler-Nichols technique is employed to find the optimum PID gains. Initially, the integral and derivative gains were set to zero and ultimate gain ( $K_u$ ) and ultimate period ( $T_u$ ) were determined from the graph. The Routh-Hurwitz criterion is then used to determine the range of proportional gain ( $K_p$ ). Upon substitution of these in the Ziegler-Nichols tuning table the following optimum values of PID controller gains are obtained:

$$\begin{aligned} K_p &= -0.0996, \\ K_i &= -0.052, \\ K_d &= -0.046. \end{aligned}$$

The simulation is conducted in MATLAB Simulink package for single area power system with PID controller. The step function is applied at  $t = 0.01$  second. From the simulation, we can note that the steady state error is nullified. The settling time is 2.459 second and peak overshoot obtained is 0.543%.

#### V. GENETIC ALGORITHM

A genetic algorithm is an optimization algorithm which mimics the process of natural evolution. It is a nature inspired approach based on Darwin's theory of survival of the fittest. It is used to find optimal or near-optimal solutions to difficult problems. The genetic algorithm begins with no knowledge regarding the exact solution and depends entirely on responses from its environment and evolution operators (i.e. reproduction, crossover and mutation) to obtain best solution [6]. Initially a random population consisting of 20 to 100 individuals is taken into consideration. This population is represented by real number values or a binary string. This string is called chromosome, which signifies one possible solution to the problem and each string bit is called a gene. Thus, the gene is the smallest unit in genetic algorithm, which denotes a unit of information in the problem domain [7]. In genetic algorithm, changes are introduced in the population through the processes of selection based on a fitness function and alteration using mutation and crossover. The application of

selection and alteration leads to a population with a higher proportion of improved solutions. The algorithm continues to iterate until an optimum solution is obtained in the current generation of population or when there is an increase in the regulator parameter such as number of generations.

##### A. Genetic Algorithm Process

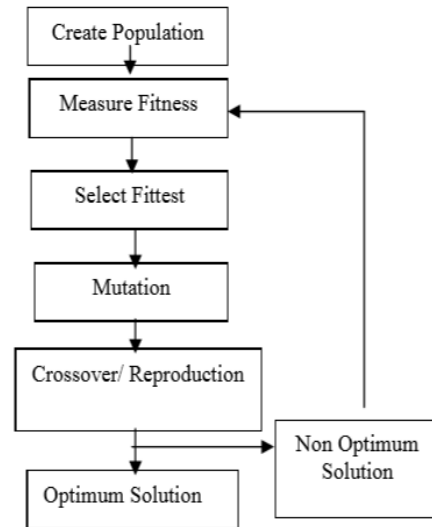

Fig. 3 Graphical illustration of genetic algorithm outline

The following 5 phases are considered in a genetic algorithm

1. *Initial Population:* The process begins with a set of individuals called as population. Everyone is a solution to the problem we want to solve. An individual is characterised by a set of parameters known as genes. Genes are combined to form a chromosome. Usually binary values are used for the representation.
2. *Fitness Function:* The fitness function determines the fitness or ability of an individual to compete with other individuals. A final score to each individual is given by the fitness function. The probability that an individual will be selected for reproduction is based on this fitness function.
3. *Selection:* In biological evolution, only the fittest members will survive, and their gene pool contributes to the creation of the succeeding generation. Selection in genetic algorithm is also based on a similar process. Here, a fitness function is taken into account which becomes an essential pre-requisite for the individuals to qualify. Every individual's likelihood of being selected as a decent one is proportional to its fitness value.
4. *Crossover:* The process of crossover is regarded as artificial mating in which chromosomes from two different individuals are combined to create the chromosome for the succeeding generation. A random crossover point is considered on each of the two chromosomes and the chromosomes are spliced. Crossover is achieved by swapping the sliced parts.

Hence genes with good characteristics from one chromosome combine with genes with good characteristics of another chromosome to create a better solution which is represented by the new chromosome.

5. *Mutation*: Mutation is regarded as the process of altering the genetic composition of a chromosome. It is essential for incorporating new characteristics in a population. This is not achieved by mere crossover, which reorders prevailing characteristics to give new combinations.

The steps involved to create and implement a genetic algorithm are as follows

1. Generation a random population of individuals for a fixed size.
2. Evaluation of their fitness by subjecting them to a fitness function.
3. Selection of the fittest members of the population.
4. Reproduction using a probabilistic method.
5. Implementation of crossover operation on the reproduced chromosome.
6. Execution of mutation operation with low probability.
7. Repetition from the second step until a predefined convergence criterion is met.

### VI. EVALUATION OF PID GAINS

The genetic algorithm is used to evaluate the optimum gains of PID controller. The gains of the PID controller  $K_p$ ,  $K_i$  and  $K_d$  are the three variables whose optimum values are evaluated. The genetic algorithm is carried out in MATLAB with the help of genetic optimization toolbox. The population of the genetic algorithm is set to a value of 50 with variable bounds of each of the three gains, obtained from the Ziegler-Nichols tuning technique, which are follows

$$\begin{aligned} -0.0996 < K_p < -0.018, \\ -0.052 < K_i < -0.0086, \\ -0.0468 < K_d < -0.00922 \end{aligned}$$

Upon execution of genetic algorithm, the evaluated optimum gain values are as follows

$$\begin{aligned} K_p &= -0.0180, \\ K_i &= -0.086, \\ K_d &= -0.0092. \end{aligned}$$

### VII. SIMULINK MODEL

The Simulink model for Genetic Algorithm is same as in Fig. 1.

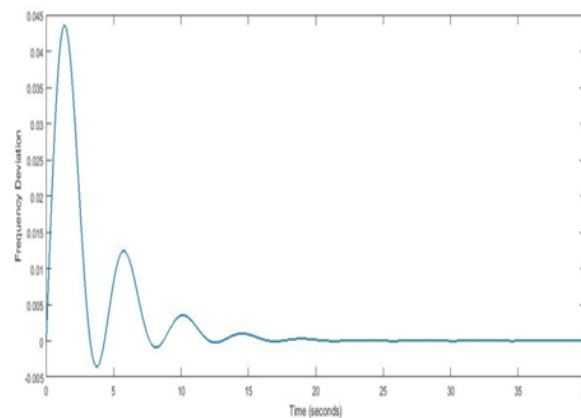

Fig. 4 Output waveform of genetic algorithm

### VIII. SIMULATION STUDY

The simulation is conducted in MATLAB Simulink package for single area power system with PID controller. The step function is applied at  $t = 0.01$  second. From the simulation, we can note that the steady state error is nullified. The settling time is 2.233 second and peak overshoot obtained is 0.505%.

### IX. CONCLUSION

In this study, the proportional integral derivative controller tuned using Ziegler-Nichols technique and Genetic Algorithm has been investigated for automatic load frequency control of a single area power system. The Simulink package for single area power system with PID controller is developed using MATLAB. The simulation result shows that the proportional integral derivative controller tuned via Genetic algorithm offers less settling time and no steady state error.

### REFERENCES

- [1] K. P. Singh Parmar, S. Majhi, and D. P. Kothari, "Optimal Load Frequency Control of an Interconnected Power System", *MIT International Journal of Electrical and Instrumentation Engineering*, Vol. 1, No. 1, pp. 1-5, Jan. 2011.
- [2] P. Kundur, *Power System Stability and Control*. New York: McGraw-Hill, 1994.
- [3] Adil Usman and B. P. Divakar "Simulation Study of Load Frequency Control of Single and Two Area System", *IEEE* 2012.
- [4] I. J. Nagrath and D. P. Kothari, *Power System Engineering*, J. McGraw-Hill, 2008.
- [5] Ashok Singh and Rameshwar Singh, "Load-Frequency Controller of electrical Power plant using Ziegler-Nichols (ZN) tuning controller", *International Journal of Innovative science, Engineering & Technology*, Vol. 1, No. 6, August 2014.
- [6] Neha Modi, Manju Khare and Kanchan Chaturvedi, "Performance Analysis of Load Frequency Control in Single area Power System Using GA and PSO Based PID Controller", *International Journal of Electrical, Electronics and Computer Engineering*.
- [7] Whiteley, "A Genetic Algorithm Tutorial", Technical Report CS-93-103, Dept. of Computer Science, Colorado State University, 1993.