

# IoT Based Garbage Monitoring and Street Light Control

K.Bagya Lakshmi<sup>1</sup>, M. Suresh Kumar<sup>2</sup>, S.Sindhuja<sup>3</sup>, R. Padmavathy<sup>4</sup> and P. Jayabharathi<sup>5</sup>

<sup>1&5</sup>Assistant Professor, Department of Electronics and Communication Engineering,

<sup>2&3</sup>Assistant Professor, Department of Computer Science and Engineering,

Sri Ranganathar Institute of Engineering and Technology, Athipalayam, Coimbatore, Tamil Nadu, India

<sup>4</sup>Project Manager, TheBharath Social and Research Foundation, Coimbatore, Tamil Nadu, India

E-Mail: bagiraviram@gmail.com, sureshkumarm1983@gmail.com

(Received 1 September 2018; Revised 22 September 2018; Accepted 12 October 2018; Available online 20 October 2018)

**Abstract** -The idea is to create a system based on Smart City.In the present day scenario, many times we see that the garbage bins or dust bins placed at public places in the cities are overflowing due to increase in waste every day. It creates unhygienic condition for the people and creates bad smell around the surroundings.This leads in spreading some deadly diseases & human illness, to avoid such a situation we are planning to design an IoT Based Garbage Monitoring System for Cities.In this proposed System there are multiple dustbins located throughout the city.They are fitted with a special type of sensors known as ultrasonic sensor which is used to detect the level of garbage in these dustbins.This data is then send to the Arduino microcontroller,which receives this data.This is send to the IoT board via a level converter.The IoT board uses a sim card for transfer of data to the cloud.The garbage values are continuously updated in the web page. A unique ID will be provided for every dustbin in the city so that garbage level can be monitored.These details can be accessed by the concerned authorities from their place with the help of Internet and an immediate action can be made to clean the dustbin.When the dustbin is full a message is also send via GSM to the concerned authorities.Along with this we incorporate the concept of Street Light Control. The street lights will be automated for switching ON and switching OFF based on intensity of sunlight using LDR.It helps to automatically turn on the street light when it is dark and automatically turn it OFF when there is light.It can also be controlled remotely using a web page. In case of any fault in a street light concerned authority will get the notification.This system of street light control uses a driver circuit to drive the low power from Arduino microcontroller to regulate the current flow.Here additionally a relay is used to control the turning ON and OFF of the streetlight.

**Keywords:** Internet of Things, Ultrasonic Senso, LDR, GSM

## I. INTRODUCTION

Internet is the trendsetter of the new era and everything in day to day life is made easy using this advancement. In order to aid the tedious work and to serve the mankind,today there is a general tendency to develop an intelligent system.To add to this global trend the proposed system of "IoT based garbage monitoring and street light control" has been designed and developed to accomplish the various tasks in the current world to make things smart. In this research work we propose to create a prototype of smart city which will integrate control garbage collection system and street light monitoring. The intelligent system is loaded with sensors,microcontroller,relay,driver circuit,level

converter,GSM and IoT board which work with the help of a start of the art microcontroller.We have used Arduino microcontroller. It is the heart of the device which handles all the sub devices connected across it. In Smart garbage monitoring system each garbage bin will have an ultrasonic sensor which continuously monitors the garbage level and transmits this data to a cloud.This can be monitored using a webpage.Whenever garbage level crosses a certain threshold level the concerned authority will be notified through a message so that garbage can be collected.The street light will be turned ON and turn OFF automatically based on intensity of light.Further a system is developed in which a web page is created and the street lights can be turned ON and OFF using the web page.The street light can also be controlled remotely using a webpage.In case of any fault in a street light,concerned authority will get the notification.The messages are sent using GSM technology.

## II. LITERATURE SURVEY

### A. Smart Dustbins for Smart Cities

For these smart cities to be smarter it is necessary that the garbage collection system has to be smarter and in addition to the people need easy accessibility to the garbage disposing points and garbage collection process has to be efficient in terms of time and fuel cost.The proposed system provide an IT based solution to garbage collection providing greater accessibility, planning appropriately for disposing process and at the same time enabling collection of garbage generation data.Here the data is collected according to scheduling process. This layer consists of internet and Wi-Fi enabled dustbins. Every dustbin contains a sensor which senses the fill up status of dustbin and sends the data to the server. It also sends its current GPS location to the server at regular intervals.Server collects the fill up status and location of dustbins. It processes the clients query and it respond with nearest dustbin location and with direction to access dustbin.

### B. Smart Bin Implementation for Smart Cities

The distance in cm measured by the ultrasonic sensor, the time taken by the sound wave to echo back to the receiver in seconds. Thus, an equation is computed by the microcontroller and we can get the distance of any solid waste material present in the

bin. The GSM module connected to microcontroller sends this garbage level in the form of text message to the central waste office. The GSM module has got a unique SIM card and a unique number, which acts as a unique ID for the respective smart bin. The garbage collection team collects the garbage from these central bins in their trucks. Accordingly, the text messages indicating the levels are being sent to the central office, which acts as a data warehouse for all the level data being sent by the different bins. The central office of waste management department will be able to track the level of every dustbin getting filled up just by sitting in their office at real time. SMS received from the GSM modules of our dustbin is taken in the form of text files. The text file is connected to the excel sheets. The updated values of the dustbin level are taken to form the real time report. The excel application designed creates a real time dashboard along with a time series graph which shows the current trend as well as the historical trend of waste level in that particular smartbin.

### *C. IOT Based Smart Garbage and Waste Collection Bin*

A project called IoT Based Smart Garbage and Waste Collection bins is being implemented for garbage management in cities. Smart collection bin works in the similar manner with the combination of sensors namely weight sensor and IR sensor that indicates its weight and different levels respectively. The IR sensors will show us the various levels of garbage in the dustbins and also the weight sensor gets activated to send its output ahead when its threshold level is crossed. These details are further given of the microcontroller (ARM LPC2148) and the controller gives the details to the transmitter module (Wi-Fi module). At the receiver section a mobile handset is needed to be connected to the Wi-Fi router so the details of the garbage bin are displayed onto the HTML page in web browser of our mobile handset.

### *D. Smart Garbage Collection Bin overflows Indicator using IoT*

In our city many times we see that the garbage bins or dustbins placed at public places are overflowing. It creates unhygienic conditions for people. Also it creates ugliness to that place. At the same time bad smell is also spread. To avoid all such situations we are going to implement a project called Garbage collection bin overflow indicator using IoT (Internet of Things) technology. In this project we are going to place a sensor (Infrared sensor/ proximity sensor) under the dustbin. When the sensor signal reaches to the threshold value, a mail notification will be sent to the respective Municipal / Government authority person. We can also see the density of the Dustbin through internet on a Dashboard, this is a GUI (Graphical User Interface) dashboard so any of the authenticate person will easily check the present condition of the dustbin. So then that person can send the collection vehicle to collect the full garbage bins or dustbins.

### *E. Internet of Things Based Intelligent Street Lighting System for Smart City*

This project aims for designing and executing the advanced development in embedded systems for energy saving of street lights. This project gives solution for electrical power wastage. Also the manual operation of the lighting system is completely eliminated. The proposed system provides a solution for energy saving. This is achieved by sensing and approaching a vehicle using an IR transmitter and IR Receiver couple. Upon sensing the movement the sensor transmits the data to the microcontroller which furthermore the Light to switch ON. Similarly as soon as the vehicle or an obstacle goes away the Light gets switched OFF as the sensor senses any object. Whenever the obstacle is detected on the street within the specified time the light will get automatically ON/OFF according to the obstacle detection and the same information can be accessed through internet. The real time information of the street light (ON/OFF Status) can be accessed from anytime, anywhere through internet.

### *F. Garbage and Street Light Monitoring System Using Internet of Things*

We are using a concept of Internet of Things in this project. So, continuous monitoring of garbage bins will help to keep environment clean and safe. This paper also includes Street light monitoring which avoids accidents during night. Hence this paper will help to reduce power consumption and manpower. In this paper, a Camera will be placed at every garbage collection point along with load cell sensor at bottom of the garbage can. The camera will take continuous snapshots of the garbage can. A threshold level is set which compares the output of camera and load sensor. The comparison is done with help of microcontroller. After analysing the image we get an idea about level of garbage in the can and from the load cell sensor we get to know weight of garbage. Accordingly information is processed that is controller checks if the threshold level is exceeded or not.

### *G. Smart City*

There is a smart garbage bin which senses the weight of the garbage & level of the garbage filled so the concerned authorities will be notified automatically when the bin is about to be filled. The street light will be intelligent enough to turn on & off automatically depending upon the sunlight intensity change i.e. summer/winter. It will enter into power saving when no traffic is there. It will sense traffic & turn on the lights temporarily. So huge amount of energy is conserved. The light will also have on fault detection mechanism & will alert the authorities when there is a fault in street light. The adaptive traffic signals are an effective way of handling traffic. Each traffic signal will analyse the density of vehicle on a particular road & adjusts the timing of red & green light of traffic signal. A green channel will be provided for ambulance the traffic data will be uploaded to the cloud to determine any emergency situation like riots, floods or natural colony based on traffic pattern.

### III. PROBLEMDESCRIPTION

In the above surveys we have come across various drawbacks depending on the timeliness of the system, cost, ease of access and also complicated hardware and algorithm usage. So our objective is to create a project to support the government's Swachh Bharath Abhiyan campaign and the concept of Smart city by providing such a system which will be both cost effective and easy to implement. Hence our problem statement is to design a system based on any microcontroller for collecting the garbage from particular area whose public garbage bins are overflowing with prior concern. So, continuous monitoring of garbage bins will help to keep the environment clean and safe. We are also aiming at creating a street light which automatically turns ON and OFF according to lighting conditions and which can also be controlled using a web page from any place.

#### A. Assumption

Ultrasonic Sensors is used to detect the obstacles and also we use LDR for light control. Here we use Arduino 1.8.1 software and arduino microcontroller unit to perform an embedded operation. This project is designed in a client server model. Where one acts for acquiring and transmitting the information while the other for data interpretation and control.

#### B. Proposed System

1. Here in this proposed system an intelligent smart bin is designed which continuously monitors the garbage which and which sends this information to a web page and can be monitored in realtime.
2. A GSM module is also attached to this which will send the information to the authorized person if the garbage is full.
3. Along with this a street light control system is given automatically control the street lights using LDR and a web page is developed such that we could ON and OFF the system from any place around the world.

#### C. Equations

The Ultrasonic Sensor sends out a high-frequency sound pulse and then times how long it takes for the echo of the sound to reflect back. The sensor has 2 openings on its front. One opening transmits ultrasonic waves, (like a tiny speaker), the other receives them, (like a tiny microphone). The speed of sound is approximately 341 meters (1100 feet) per second in air. The ultrasonic sensor uses this information along with the time difference between sending and receiving the sound pulse to determine the distance. It uses the following mathematical equation.

$$\text{Distance} = \text{Time} \times \text{Speed of Sound} \text{ divided by } 2$$

Time = the time between when an ultrasonic wave is

transmitted and when it is received. You divide this number by 2 because the sound wave has to travel to the object and back. Key applications include level sensing, flow metering, distance sensing, air in line (bubble detection) and sonar.

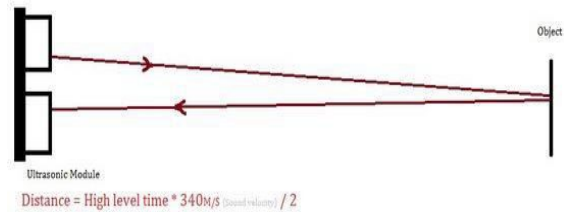

Fig. 1 Ultrasonic sensor distance Measurement

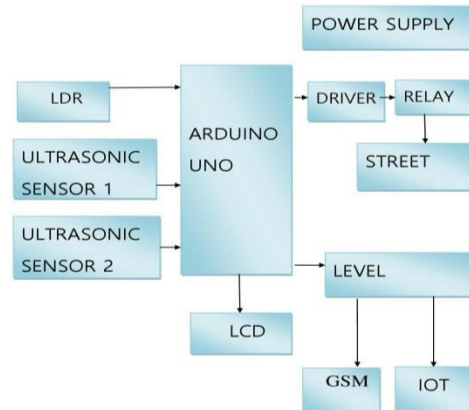

Fig. 2 Block diagram of the proposed system

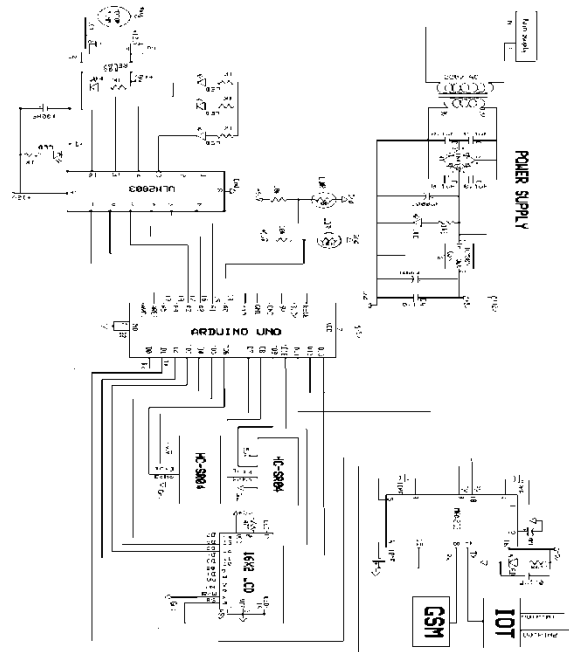

Fig. 3 Circuit diagram of the proposed system

### IV. METHOD AND MATERIALS

The method or working principle is mainly dependent on ultrasonic sensor functioning and LDR. This is actually much a simple method to implement in the hardware part, and doesn't need much complications. It is cost

effective and simpler hardware components are used.

### A. Microcontroller ArduinoUno

Microcontroller Arduino Uno is the heart of the system and controls all the functions of the system. For garbage monitoring it receives the data from ultrasonic sensor and sends it via IoT board through the cloud which can be monitored with the help of a webpage. The microcontroller is programmed in such a way that when the light is ON through the web page the pin associated with the light in the microcontroller goes high and the bulb glows and when it is OFF the pin goes low and the bulb is OFF. When there is any fault with the light a message will be sent to the authorities that the bulb is not glowing via GSM. The turning OFF and ON can also be controlled with the help of a web page through the microcontroller.

#### 1. For Garbage Monitoring

**a. Ultrasonic Sensor:** It detects the amount of trash and sends this information to the microcontroller. This is done by sending out a high-frequency sound pulse and then times how long it takes for the echo of the sound to reflect back. The microcontroller receives this data through its pins D6, D7, D8 and D9. It transmits this data to cloud by using IoT board through its D11 and D12 pins. This value of garbage level is continuously updated in the cloud and can be monitored using a webpage

**b. LCD:** The LCD 16\*2 display unit placed near the garbage also displays the amount of space remaining in the dustbin in order for it to be full. It is connected to the microcontroller via pins D2-D3.

**c. GSM:** A GSM (pins from D0-D1) is attached to this which will send the message to the authorities once the dustbin is full.

**d. Level Converter:** A level converter MAX232 is used to interface this GSM unit to this system. In case any notification comes like the “Dust bin is full” or “Street Light is not glowing”, the level converter gives the control to GSM to send the message.

#### 2. For Street Light Control

**a. LDR:** In the street light control system the LDR senses the intensity of light. If the intensity is below a certain level it will automatically turn ON the light. And when enough light is there it automatically turns OFF. An LDR value is already set in the microcontroller, if it exceeds that value the bulb will turn ON otherwise it will turn OFF.

**b. Driver:** This system of street light control uses a driver circuit to drive the low power from Arduino microcontroller to regulate the current flow

**c. Relay:** Here additionally a relay is used to control the turning ON and OFF of the street light.

### B. Software Unit

For the software unit we have used Arduino 1.8.1 software. The microcontroller is programmed using this and this is already pre-programmed or fed to the microcontroller. The whole system control lies in this. The microcontroller works according to this. Then a webpage is created which sends the data using HTTP GET method. This web page is used to display the garbage amount, date and the time.

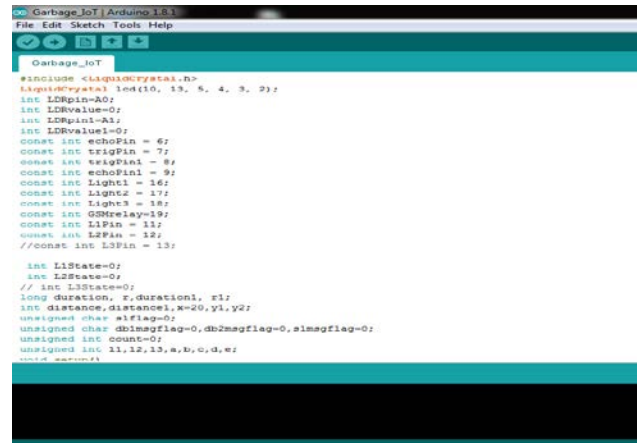

Fig. 4 Programming in Arduino 1.8.1



Fig. 5 Result of the developed system on LCD

### D. Working

The power supply is used to provide 2 types of voltages to different components, 12v and 5v. First 220v AC power supply is given. This is fed to the step-down transformer which converts this into 12v DC. This helps to feed the system components with the required amount of current. Rectifier diode IN4007 is used to ensure voltage flow in one direction. Filters are used to remove ripples or any other unwanted frequency components from the signal to enhance wanted ones to make the power signal a pure one. IC7805 which functions as a regulator regulates the power supply. This power supply serves as 12v and 5v according to the requirement of component specifications. The ultrasonic sensor HC-SR04 senses the level of garbage. This economical sensor provides 2cm to 400cm of non-contact measurement functionality with a ranging accuracy that can reach up to 3mm. Each HC-SR04 module includes an ultrasonic transmitter, a receiver and a



control circuit. There are only four pins : VCC (Power), Trig (Trigger), Echo (Receive), and GND (Ground). This measures the distance using a formula and transmits this to the Arduino Uno microcontroller. The microcontroller receives this via analog pins and digitizes it. This is sent further to the IOT board via a level converter. The level converter MAX 232 increases the voltage from microcontroller i.e 5v to 12v, It converts the TTL voltage levels to RS232 level and vice versa. So the max232 acts as a charge pump and does the conversion either way. This output is displayed in the webpage including date and time. The webpage is also being constantly updated with the garbage values. The amount of space remaining is also displayed using an LCD screen. For street light control the LDR works according to light intensity. The microcontroller is programmed in such a way that when the resistance crosses a certain value the bulb glows otherwise it turns off. This system is also designed in such a way that we can also control the street lights using a webpage as well. When the switch in the webpage is made ON then the trigger input goes high in the pin of Arduino which will make the resistance high and thus the Light turns off. When the switch is made OFF the Arduino input goes low and the light is turned ON. This can be implemented in two systems, either the light should be made automatic using LDR or it should be controlled using a webpage. Both ways suggest a smart way of handling the street light control. A Driver is used to control the LDR circuit and a relay is used for mechanical switching ON and OFF of the light.

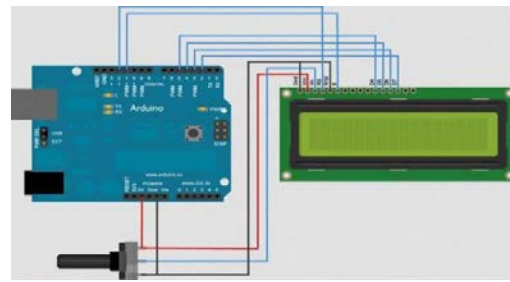

Fig. 8 Interfacing microcontroller with LCD

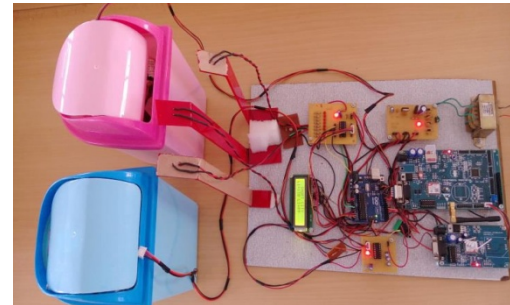

Fig. 9 Pictorial view of developed system

**V. CONCLUSION**

The proposed system based on Arduino microcontroller is found to be more compact, user friendly and less complex, which can readily be used in order to perform tedious tasks that are repetitive. Due to the probability of high technology used in this project “IoT based garbage monitoring and street light control” is software controlled with less hardware circuit. The feature makes this system the base for future systems. By implementing this project we will avoid overflowing of garbage from the containers in cities by monitoring it continuously. So it helps in contributing to a better environment. It can also automatically and manually monitor the street lighting equipment’s which helps in less energy consumption and reduced manpower.

**REFERENCES**

- [1] Bikramjith Singh and Manpreetkaur, “Smart Dustbins for Smart Cities”, *International Journal of Computer Science and Information Technology*, Vol. 7, No. 2, 2016.
- [2] Narayan Sharma, Nirman Singha and Tanmoy Dutta, “Smart Bin Implementation for Smart Cities”, *International Journal of Scientific and Engineering Research*, Vol. 6, No. 9, 2015.
- [3] Parkash Prabu, “IoT Based Waste Management for Smart City”, *International Journal of Innovative Research in Computer and Communication Engineering*, Vol. 4, No. 2, 2016.
- [4] Savan Vyas, Mahendra Arutla and Rishikesh Ayre, “Smart City”, *National Conference on Science Engineering and Technology*, Vol. 4, No. 6, 2016.
- [5] Prof. R.M Sahu, Akshay Godase, Pramod Shinde and Reshma Shinde, “Garbage And Street Light Monitoring System Using IoT”, *IJIREICE*, Vol. 4, No. 4, 2016.
- [6] S.S. Navghane, M.S. Killedar, V.M. Rohokale, “IoT Based Smart Garbage And Waste Collection Bin”, *International Journal of Advanced Research for Electronics and Communication Engineering*, Vol. 5, No. 5, 2016.
- [7] Vishesh Kumar Kurre, “Smart Garbage Collection Bin Overflows Indicator Using IoT”, *International Research Journal of Engineering and Technology*, Vol. 3, No. 5, 2016.



Fig. 6 Output webpage for street light control

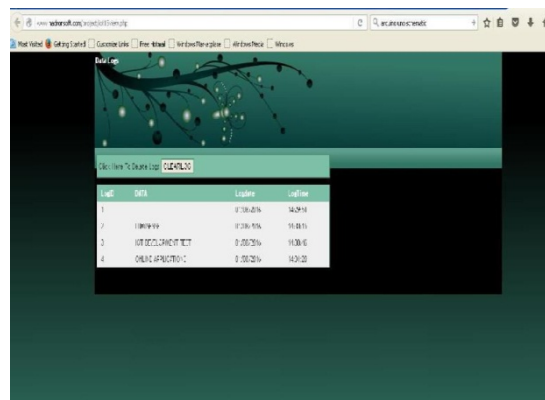

Fig. 7 Output webpage for garbage monitoring