

Competent Realization of Co-Operative Spectrum Sensing in Cognitive Radio Systems

M. S. Pavithra¹, S. Karthikeyan², V. J. K. Kishor Sonti³ and S. Jayashri⁴

^{1,2 & 3} Department of ECE, Sathyabama University, Chennai - 600 119, Tamil Nadu, India

⁴Department of ECE, Adhiparasakthi Engineering College, Melmaruvathur, Tamil Nadu, India

E-mail : pavithraa590@gmail.com, karthijoyz@gmail.com

(Received on 21 August 2012 and accepted on 18 October 2012)

Abstract – Cognitive radio is widely expected to be the next Big Bang in field of wireless communications. The objective of cognitive radio is to enhance the spectrum utilization efficiency. Spectrum sensing, a challenging task of cognitive radio helps in opportunistic spectrum access. Co-operative spectrum sensing mitigates these effects of fading, shadowing and uncertainties in normal sensing at the cost of energy consumption. Energy consumption in Co-operative spectrum sensing is due to computation of full spectrum FFT. This paper aims at the design of co-operative spectrum sensing unit in a cognitive radio system. It present a coprocessor for computing reduced point FFT, a block for the detection of spectrum hole, a fusion center for combining the decision from different users and a special prediction block for improving performance of Co-operative spectrum sensing. This idea reduces the computation to one fourth. The simulations are done using Xilinx ISE design suit 12.1 and ModelSim and synthesized using VerilogHDL.

Keywords : Cognitive Radio, FFT, Spectrum Sensing, Energy Detection, Fusion Center

I. INTRODUCTION

The growing demand of wireless communication systems in recent years has lead to serious competition over scarce spectrum resources. The Electromagnetic Radio Spectrum is currently licensed by regulatory bodies for various applications. The need for higher data rates is increasing as a result of the transition from voice-only communications to multimedia type applications. The conventional approach to spectrum management is very inflexible in the sense that each operator is granted an exclusive license to operate in a certain frequency band. However, with most of the useful radio spectrum already allocated, it is becoming exceedingly hard to find vacant bands to either deploy new services or enhance existing ones. Thus static frequency allocation schemes cannot accommodate the requirements of an increasing number of higher data rate devices. Hence there is a severe shortage of the spectrum for new applications

and systems. However, field test indicates that most of the spectrum resources are underutilized in the licensed bands. At any time and place, very little of the licensed spectrum is actually underutilized. The unutilized part of the spectrum results in 'Spectrum holes' or 'White Spaces'. [1] Recently it has been proposed to allow the utilization of unused spectrum at times by the users who do not hold any license.

A. Cognitive Radio

Cognitive Radio has a potential to become the solution to the spectrum underutilization problem without disturbing the licensed user's functionalities.

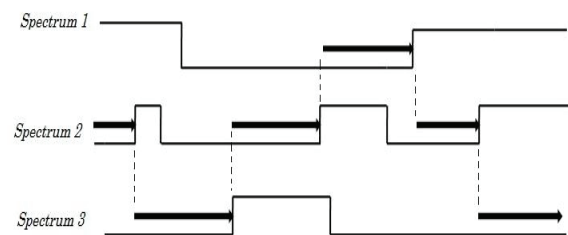

Fig 1 Dynamic Spectrum Access

The Federal Communications Commission (FCC) defines the Cognitive Radio as: "Cognitive radio: A radio or system that senses its operational electromagnetic environment and can dynamically and autonomously adjust its radio operating parameters to modify system operation, such as maximize throughput, mitigate interference, facilitate interoperability, access secondary markets" [2]. The literal meaning of "Cognitive" is remembering, thinking and reasoning. Stating simply, it is radio systems which analyses the Radio Environment, identify the spectrum holes and then operate in those holes. Fig1 depicts how system dynamically uses spectrum holes or white spaces, which are temporarily not used in space, time and/or frequency.

The DSA adopted by Cognitive Radio systems is more effective when the spectrum sensing is Co-operative in nature rather than Non co-operative sensing.

B. Co-operative Spectrum Sensing

Co-operative spectrum sensing in CR in a centralized architecture groups the users into two classes namely, busy user and idle users. Busy users are those that sense the spectrum continuously and use the spectrum where, idle users do not use the spectrum but the help the busy user in efficiently sense the spectrum. Co-operative spectrum sensing is impractical because, the busy user spends most of its energy in sensing the spectrum and hence its battery drains before it really want to communicate using its spectrum. The more energy consumption by idle users is because of the computation of FFT in sensing operation.

Many researches are now concentrated in making the co-operative spectrum sensing in CR. Most of the approaches for improving the processing architecture in CR save the data transmission and reception power and do not concentrate on reducing the power consumed for sensing the spectrum. Recent researches in signal processing develop a number of architectures for FFT processors which is an important block in many systems.

An efficient FPGA implementation of FFT/IFFT Processor [3], presents a radix-2² FFT architecture considering the execution speed as the main concern. But this architecture when analyzed for power consumed in accordance with the operating frequency. The architecture for a FFT processor can be either pipelined, parallel or shared memory architecture. He pipelined and parallel architectures provide a high speed and have a good throughput for large point FFT also, but the area for the hardware o be deployed is more. Whereas in shared memory architecture area is less but the throughput gets worse as the number of point FFT increases.

This paper concentrates on providing an energy efficient architecture for co-operative spectrum sensing in cognitive radio system. Idea of computing FFT for reduced point and predict the un-computed values, as shown in [4] are used here in cognitive radio systems.

II. REDUCED POINT FFT PROCESSOR

The FFT processor in this paper is adopted from the partial cached FFT processor used in OFDMA subcarrier demodulation presented in [4]. However the FFT processor here replaces the normal multipliers with complex multipliers, because the processing deals with signals and hence there is a chance for complex numbers to exist.

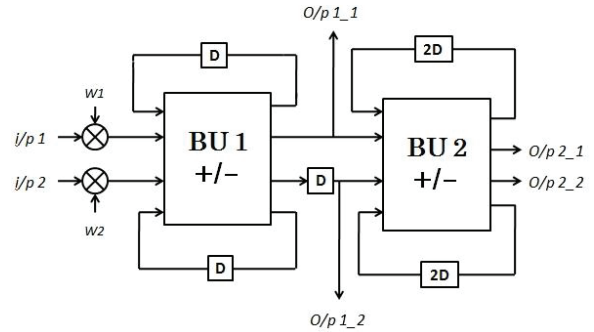

Fig 2 Reduced point FFT Processor Architecture

The Reduced FFT processor consists of two butterfly units pipelined with delay elements. Each butterfly unit is capable of performing one Radix-2 FFT operation. The complete FFT processor is designed for the computation of 4-point FFT as per system specifications. Fig 2 shows the architecture of Reduced Point FFT Processor.

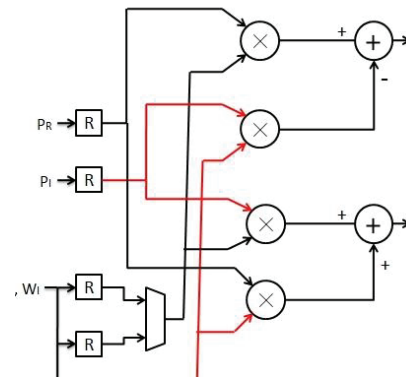

Fig 3 Complex Multiplier Unit

The multiplier in FFT processor is a complex multiplier as shown in Fig 3. The complex multiplier shown maintains the real and imaginary parts separately throughout the computation. Let P be the inputs where we consider it to be complex valued. W be the twiddle factor which is also considered to be complex number.

$$\begin{aligned}
 WP &= [W_R + jW_I] [P_R + jP_I] \\
 &= W_R P_R + jW_R P_I + jW_I P_R - W_I P_I \\
 &= W_R P_R - W_I P_I + j[W_R P_I + W_I P_R] \\
 &= [A-B] + j [C+D] \\
 &= E + jF
 \end{aligned}$$

This complex multiplier structure is special because it is based on four real-valued [13]. There are number of architectures for performing complex multiplication but he

the advantage gained in this architecture is that the critical path of the complex multiplier, i.e., the critical path of the butterfly unit is shortened.

III. SPECTRUM DETECTION

A number of different methods are proposed for identifying the presence of signal transmissions. Matched filter based detection, Feature detection, Radio identification based sensing and energy detection based sensing are some of the techniques for spectrum detection [8].

In this work Energy detection based sensing as shown in Fig 4 is preferred and it is most common method of spectrum sensing because of its low computational and implementation complexities. The signal is detected by comparing the output of energy detector with threshold which depends on noise floor. An energy detector simply measures the energy received on a primary band during an observation interval and declares a white space if the measured energy is less than a properly set threshold [5]. Their performance is poor under low signal-to-noise ratio (SNR) values hence energy detectors do not work efficiently for detecting spread spectrum signals [6] and [7]. These drawbacks are mitigated when they are implemented in Co-operative spectrum sensing.



Fig 4 Block diagram for Energy detection based Sensing

The performance of the detector is based on the correctness of threshold value. But, fixing the threshold value is difficult because of uncertain nature of the channel. Therefore In this work for simplicity it is assumes that the wireless environment is affected by stationary white Gaussian noise. Hence the threshold value need not be adaptive in nature.

For the computation of threshold value the idea from physics is taken. Energy of an electromagnetic wave can be calculated easily by having knowledge about its frequency using the following equation.

$$E = hf \dots \dots \dots (9)$$

Where, h is Planks constant ($6.626 * 10^{-34}$) and f is the frequency of the channel to be sensed. This computed value is the energy of a single photo in that frequency. But every particle in the world is made out of

huge number of similar atoms. Hence the obtained value is further multiplied by a huge constant.

IV. PROPOSED CO-OPERATIVE SPECTRUM SENSING (CSS)

The proposed algorithm for the CSS architecture is as shown in Fig 5. In this architecture the flow begins with the selection of frequency sub-band which has to be sensed.

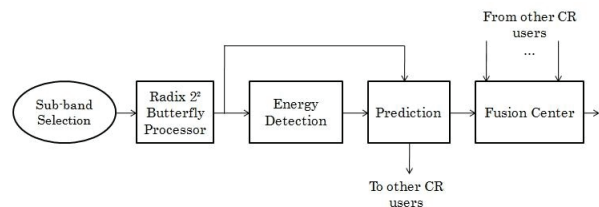

Fig 5 Co-operative Spectrum Sensing Architecture

The architecture consists of a Reduced point FFT processor for the FFT computation of selected frequencies, followed by a spectrum detection block based on energy, prediction of the un-computed frequency's energy levels and finally a fusion center which provides the actual status of the sensed band based on the sensed information from other cognitive users. This architecture helps in reducing the computation burden for spectrum sensing to one fourth.

A. System Model for Proposed Work

Assume that the cognitive radio users in total have a wide range of spectrum to operate on and the primary user exist in that range as follows

$$BWPU = \beta BWCR ; 0 < \beta < 1 \dots \dots \dots (1)$$

Where $BWPU$ is the bandwidth for the primary user and $BWCR$ is the total bandwidth of Cognitive radio.

$$FP = FC + \alpha BWCR ; 0 < \alpha < 1 \dots \dots \dots (2)$$

FP represents the lower boundary frequencies of the primary user band and FC represents the lower boundary frequencies of the cognitive user band. A parameter determines relative position between the primary and cognitive users.

Therefore, we assume that the primary user occupies a wideband in the spectrum. The spectrum ranging from 2.8 GHz to 6.7GHz is considered. One user band of 0.3GHz covers 4 successive frequencies. Thus the value of β is considered to be (3/4) 0.75.

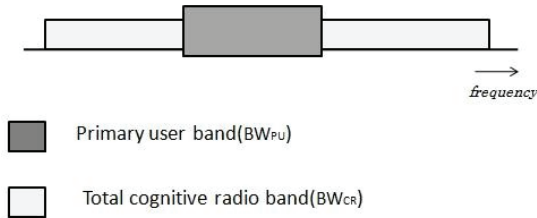

Fig. 6 Spectrum allocation

For $\beta=0.75$, number of users $N = 10$ and $BWCR = 3\text{GHz}$, $BWPU$ is computed using equation (1) as 2.25GHz .

The relative position between Primary user and Cognitive user, $\alpha = 0.25$. The lower boundary frequency of cognitive user and primary user is computed using equation (2).

B. System model for energy detection

Let us assume that the received signal has the following simple form

$$y(n) = s(n) + w(n) \dots\dots\dots (3)$$

where $s(n)$ is the signal to be detected, $w(n)$ is the additive white Gaussian noise (AWGN) sample, and n is the sample index. Note that $s(n) = 0$ when there is no transmission by primary user.

The decision metric for the energy detector can be written as

$$M = \sum_{n=0}^N |y(n)|^2 \dots\dots\dots (4)$$

where N is the size of observation vector.

The decision on the occupancy of a band can be obtained by comparing the decision metric M against a fixed threshold λ .

This comparison is equivalent to distinguishing between the following two hypotheses:

$$H_0: y(n) = w(n) \dots\dots\dots (5)$$

$$H_1: y(n) = s(n) + w(n) \dots\dots\dots (6)$$

The performance of the detection algorithm can be summarized with two probabilities: probability of detection PD and probability of false alarm PF .

PD is the probability of detecting a signal on the considered frequency when it truly is present. Thus, a large detection probability is desired. It can be formulated as

$$PD = \Pr (M > \lambda | H1) \dots\dots\dots (7)$$

PF is the probability that the test incorrectly decides that the considered frequency is occupied when it actually is not, and it can be written as

$$PF = \Pr (M > \lambda | H0) \dots\dots\dots (8)$$

PF should be kept as small as possible in order to prevent underutilization of transmission opportunities. The decision threshold λ can be selected for finding an optimum balance between PD and PF .

C. Prediction Unit

The Reduced FFT computation as the name specifies, computes only selected frequencies in the sub-band. There is a need for predicting the un-computed frequencies for further processing. The prediction can be performed by either AND-rule or OR- rule.

Fig 7 shows the full point FFT, Reduced point FFT and the predicted values. Consider the frequency band range to be sensed as 1.6 GHZ, and then 4-point FFT is computed by each idle user where only one frequency is sensed for every 0.4 GHz band and hence it is called as Reduced point FFT.

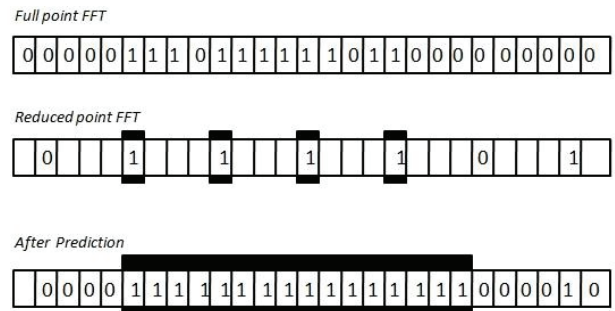

Fig 7 Full point and Reduced point FFT

The same band when sensed with full point FFT then a 16 point FFT has to be computed by each idle user which accounts for increased power consumption.

The un-computed values are predicted with more accuracy. One advantage in data prediction in his architecture is, it helps to overcome the adverse effect caused by the

frequency notches that occur in data transmission due to fading and shadowing of the channel which is uncertain in nature. This frequency notches during data transmission in full FFT spectrum sensing leads to detection error and results in interference.

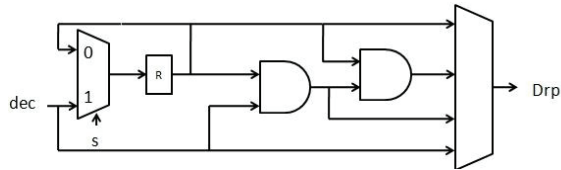

Fig. 8 Detection Prediction Unit

In this work AND rule prediction is preferred over OR rule. This is because of the idea that the secondary user may miss an opportunistic access to a spectrum but should never get access a busy spectrum. A simple AND gate can be used for this prediction. Fig 8 shows the architecture of prediction unit.

D. Fusion Center

Centralized architecture of Co-operative spectrum sensing is organized such that the sensing information from various cognitive users reach a central fusion center where it combines the data and takes a final decision about the availability of the spectrum. The fusion center takes appropriate decision based on fusion function.

Consider the sensing of a sub-band. As discussed earlier, the sub-band rang in this work is 1.6GHz. Each cognitive user senses 0.4GHz by computing 4-point FFT and then energy detection based sensing. The un-computed frequencies of the sub-band are predicted, but those frequencies are computed by other cognitive users. so, the predicted value and the computed value of a particular frequency is sent to fusion center for perfect decision about that frequency’s availability.

Two stage of fusion operation is performed. Fusion functions used in this work are OR-rule as shown in Fig.9. This rule is chosen because the aim of cognitive radio system is to access the primary user spectrum when it is available, without causing any interference to primary transmission.

The first fusion center adds the detection result of a frequency that comes from various cognitive users located at different distances, this is called as frequency bin. The bin size (B) in this work B=3. The result of first fusion center which are the fusion of frequency bins are stored in the registers before sending to the second fusion center. The values are registered because, the prediction is done by only a single gate and hence it reaches the fusion center earlier than the fusion result of the bins. Hence in order to provide a proper synchronization at the input of second fusion center registers are used.

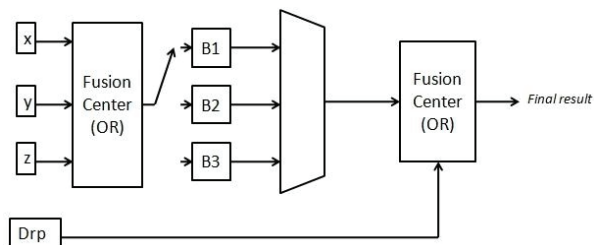

Fig. 9 Fusion Center

Even if one cognitive user detection result is ‘1’ which implies that the frequency is busy, then the fusion center result will be 1. In order to fine tune this fusion result second fusion center is used. Here also OR-rule is preferred. In the second fusion center, the result of first fusion center is ORed with the predicted value of that frequency.

V. RESULTS

In this section simulation results are presented in order to demonstrate the functioning of the architectures developed. The main aim of this paper is to develop architecture for implementing Co-operative spectrum sensing. Hence some assumptions are made during the simulation of the architecture. The simulations are done using ModelSim by developing coding in VerilogHDL in Xilinx 12.1 design suit .

A. Simulation of Complex Multiplier Unit

The complex multiplier unit referring to Fig 5 is simulated and results are verified for correctness. The simulation output is shown in Fig 10.

The inputs are $P= 2+4j$ and $W= 2+2j$, produces the result as $-4+12j$.

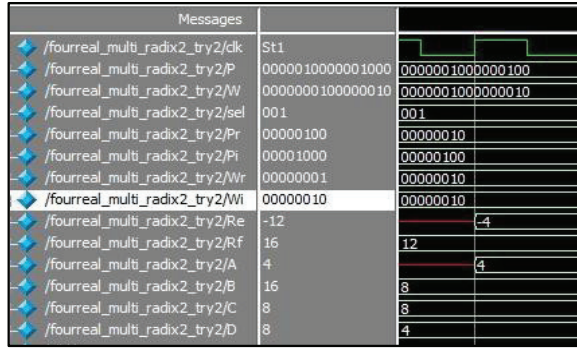

Fig. 10 Simulation Output of Complex Multiplier Unit

B. Simulation result of Reduced FFT Processor

Fig. 11 shows the simulation output of the architecture of Reduced point FFT referring to Fig 4.

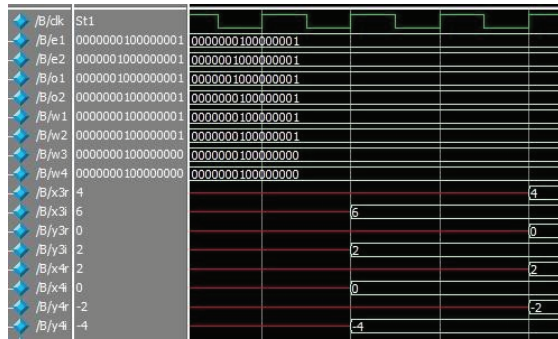

Fig 11 Reduced Point FFT

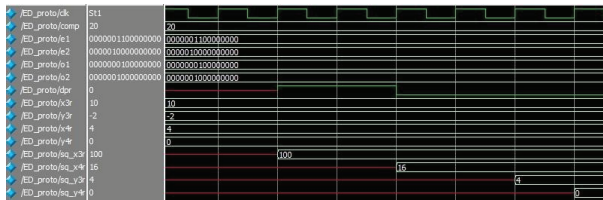

Fig 12 Simulation Result of Prototype of Energy Detection based Sensing

C. Simulation of Energy Detection Unit

For simplicity here in this work computation of Threshold value is done using equation $E=hf$. where

h planks constant (J.s)

frequency of wave (1/s)

$$E = (6.646 * 10^{-34}) * (3 * 10^9)$$

$$= 1.98 * 10^{-24} \text{ J [energy of single photon at frequency 3GHz]}$$

For convenience and to make sense in fixing the threshold value, it is multiplied by 10^{25} .

TABLE 1 INPUT OUTPUT DETAILS OF FFT PROCESSOR

Input	Twiddle Factor	Intermediate Output	Output
1+1j	1+1j	2+4j	4+6j
2+1j	1+1j	-2j	2j
2+1j	1	2+3j	2
1+1j	1	2-1j	-2-4j

TABLE 2 SPECIFICATIONS FOR PROTOTYPE OF ENERGY DETECTION BASED SPECTRUM SENSING FOR DETECTION OF WHITE SPACE

FFT size	4-point FFT
Number of Samples	4
Frequency	3GHz
Bandwidth	300MHz
Threshold Energy	20J

TABLE III INPUT OUTPUT DETAILS OF ENERGY DETECTION BASED SENSING

FFT Input	FFT Output	Squared Magnitud	Detection
3	10+7j	100	1
1	-2-5j	4	0
4	4+1j	16	0
2	-3j	0	0

The pin *drp* shows the decision whether the spectrum is occupied (1) or free (0). Fig 12 shows the simulation output.

This does not affect the operation or performance of the detector in any way. Thus the threshold is 19.8 J. This is approximated to 20J and given to the pin *comp*.

Table 3 shows the input output details of Energy detection based sensing unit, where FFT, squaring and detection are shown.

D. Simulation of Fusion Center and Prediction Unit

The Prediction block along with the Fusion center is simulated and the result is as shown in Fig 13.

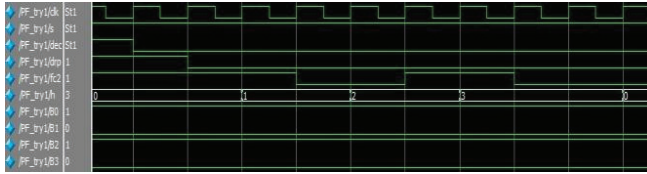

Fig 13 Simulation Result of Fusion Center and Prediction Unit

B0,B1,B2,B3 are registers holding the ORed values of bins where each bin is of size 3.*drp* is the output of AND-rule prediction which is ORed with the B register values to provide the final decision about the spectrum to *fc2*.

VI. CONCLUSION

The complete architecture presented in this paper forms an efficient spectrum sensing processor. It is efficient in the sense that the architecture suppresses the overheads incurred by the normal spectrum sensing methods. The architecture is developed for a spectrum sensing method which is co-operative and centralized in nature. The massive spectrum sensing power consumption of idle users makes cooperative spectrum sensing an impractical scheme. The idle users may use up battery energy before they really want to use the spectrum for communication. This work provides a solution for this issue. The overall idea is to provide an efficient way for making co-operative spectrum sensing a practical scheme by splitting the spectrum sensing work among the users of cognitive system. Thus this work contributed a lot to Co-operative spectrum sensing in future cognitive radio systems.

REFERENCES

[1] Amir Ghasemi Elvino S. Sousa, -Spectrum Sensing in Cognitive Radio Networks: Requirements, Challenges and Design Trade-offs, Communications Research Centre Canada and University of Toronto, April 2008.

[2] Federal Communications Commission, -Notice of proposed rulemaking and order: Facilitating opportunities for flexible, efficient, and reliable spectrum use employing cognitive radio technologies, Docket No. 03-108, Feb. 2005.

[3] Ahmed Saeed, M. Elbably, G. Abdelfadeel, and M. I.Eladawy -Efficient FPGA implementation of FFT / IFFT Processor, *International Journal Of Circuits, Systems And Signal Processing* Issue 3, Volume 3, 2009.

[4] Chao-Ming Chen, Chien-Chang Hung, and Yuan-Hao Huang, Member, *IEEE*, "An Energy-Efficient Partial FFT Processor for the OFDMA Communication System", *IEEE Transactions On Circuits And Systems—II: Express Briefs*, VOL. 57, NO. 2, FEBRUARY 2010. [5] http://www.zte.com.cn/endata/magazine/ztecommunicationz2009year/no2/articles/200907/t20090701_1_73_473.html.

[5] <http://www.radioelectronics.com/info/wireless/ieee-802-22/ieee80222-wran-standard.php>

[6] Danijela Cabric, Artem Tkachenko, Robert W.Brodersen., - Experimental Study of Spectrum Sensing based on Energy Detection and Network Cooperation -,Berkeley Wireless Research Center 2108 Allston Way #200 Berkeley.

[7] Mansi Subhedar1 and Gajanan Birajdar, *Spectrum Sensing Techniques In Cognitive Radio Networks: A SURVEY*-Department of Electronics and Telecommunication Engineering, SIES Graduate School of Technology, Navi Mumbai, India.

[8] Yonghong Zeng, Ying-Chang Liang, Anh Tuan Hoang, and Rui Zhang.,(2010)A Review on SpectrumSensing for Cognitive Radio: Challenges and Solutions-, Hindawi Publishing Corporation, EURASIP Journal on Advances in Signal Processing, Volume 2010, Article ID 381465,.

[9] Hsiao-Hwa Chen, Mohsen Guizani book on -Next generation wireless systems and networks.

[10] Vinod Sharma and ArunKumar Jayaprakasam, -An Efficient Algorithm for Cooperative Spectrum Sensing in Cognitive Radio Networks -Dept of Electrical Communication Engineering Indian Institute of Science, Bangalore.

[11] J. Cooley and J. Tuckey, -An algorithm for the machine calculation of the complex fourier series, *Math. Comput.*, Vol. 19, pp. 297-301, Apr. 1965.

[12] Jarmo Takala and Konsta Punkka, "*Butterfly Unit Supporting Radix-4 And Radix-2 FFT*",Tampere University of Technology, P.O.Box 553, FIN-33101 Tampere, FINLAND.