

Capacitive Fringing Field Sensor Design for Moisture Measurement

G. Narmadha¹, B.S. Sreeja², B. Bindu³ and M.C. John Wiselin⁴

^{1&2} Department of Electronics and Communication, SSN College of Engineering, Kalavakkam - 603 110, Tamil Nadu, India.

³ Department of Electronics and Communication, Eswari College of Engineering, Guntur, India

⁴ Immanuel Arasar JJ College of Engineering, Nattalam, Marthandam - 629 195, Tamil Nadu, India

E-mail: narmadha.ei@gmail.com, sreejaabs@gmail.com

(Received on 13 July 2012 and accepted on 23 September 2012)

Abstract – The fringing field capacitive sensor is described for moisture measurement like soil, food application. Interdigitated electrode capacitive sensor has been utilized in numerous applications at low frequency. A sensor performance was evaluated by monitoring the output capacitance variation with and without moisture content. The variation in capacitance is directly measured by using interface circuit. Switched capacitor dual slope capacitor to digital converter has been utilized as an interface circuit. The interface circuit has been designed and simulated with variable capacitance by sensor performance. Printed circuit board technology is particularly advantageous for realizing this type of sensor by fabricating the interdigitated electrode structures in the patterned Cu foil instead of realizing these type of sensors in various technologies.

Keywords: Fringing field sensor, Interdigitated electrode, Moisture measurement, DSCDC

I. INTRODUCTION

Capacitor structures can be utilized as sensors for numerous applications. The sensors can measure many physical variables (measurand) like position, accelerometer, moisture, angular speed and liquid level to detect the environmental changes. The changes in the capacitance of the sensor was monitored for any measurand that affects the electrode separation distance, the electrode overlapping area, or the relative permittivity of the dielectric in the vicinity of the electrodes. A useful sensor can be realized by additionally interacting with the fringing fields for any measurand (i.e moisture), thereby reconfiguring the electric displacement field (D) mapping and changing the measurable capacitance due to the fringing field. Fringing field capacitor sensors have the advantage of projecting the fringing field into the object or material without altering the electrode configuration. Interdigitated electrode structures are particularly suitable for this sensing technique since they can be designed to maximize the capacitance due to fringing. Capacitive sensor

uses the method of measuring changes near the sensor's surface which is considered as the distinct advantage when compared to other techniques explained in non capacitive sensor [1-5]. The capacitive sensor measurements do not possess potential health risks of radiation-based methods. Fabricating and operating low-frequency capacitive sensors are simple relatively compared to RF-based techniques. Switched capacitor dual slope capacitance to digital converter [6] is used for sensing capacitance-type sensor in several areas as they provide better sensitivity and linearity of any measurand.

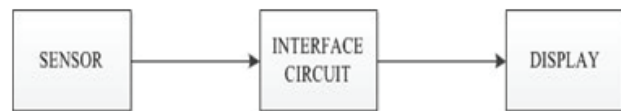

Fig. 1 Block diagram of capacitive sensor

Typical ADC possesses an analog part and a digital part which is required to interface a capacitive sensor. An analog part of an ADC itself is designed to accept the elements of a sensor and the ADC logic is appropriately modified to provide a digital output directly proportional to the parameter being sensed. An analog signal-conditioning circuit that converts the variations in the sensor capacitances to a proportional analog voltage or current is required in an analog to digital converter. Such a scheme does not require a separate analog-signal-conditioning unit. A direct conversion method provides an output proportional to the ratio of two capacitances which is suitable for differential capacitive sensors has been proposed in [7]. Hence, direct conversion method can observe a small range of variations in the capacitances of the sensor. A novel switched-capacitor dual-slope technique that converts the variations in the capacitances C_1 and C_2 of a differential capacitive sensor directly into a proportional digital value based on a ratiometric approach was presented [8]. The proposed dual-slope CDC (DSCDC) offers an advantages of negligible sensitivity toward various error sources, such as stray capacitances, switch leakage currents, and op-amp

offset voltage, high speed in comparison with the delta sigma interface circuit[9] and charge amplifier circuit[10]. Moreover, this method requires only a single dc reference voltage and hence avoids errors arising out of mismatched dc reference voltages (offset voltage) of opposite polarity, which is a major source of error in the triple-slope CDC scheme.

II. INTERDIGITATED ELECTRODE STRUCTURE

Consider a structure where n plates, referred to as electrode teeth, of area, a , are stacked in parallel, a fixed separation distance, d , apart, in a dielectric material of relative permittivity, ϵ_r , as illustrated in the top-view drawing in Fig. 2. Every other electrode tooth is electrically connected together through a common electrode arm. This electrode configuration is referred to as two interdigitated electrodes. In the drawing, "A" and "B" are the electrical contacts to the two interdigitated electrodes.

If the magnitude of the overlapping tooth area is much greater than the electrode separation distance, most of the capacitance between opposing teeth is due to electric flux directly between the electrode overlapping areas and is not due to fringing effects. However, since the perimeter around the teeth is much greater than the perimeter around two parallel plate electrodes of the same total overlapping area with the same electrode separation distance, the fringing effects will be considerably greater in the interdigitated electrode case.

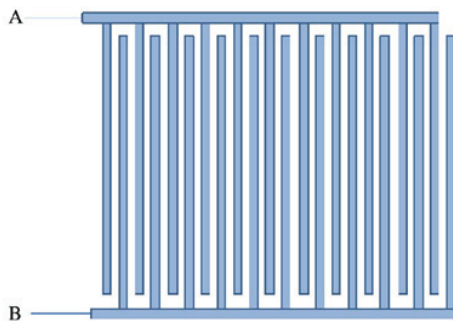

Fig. 2 Top view of interdigitated electrodes

For n interdigitated electrode teeth, the equation for the capacitance can be approximated as

$$C = \epsilon_r \epsilon_0 a \gamma / d \quad (1)$$

where ϵ_0 is the permittivity of free space, 8.854 pF/m, and γ is the fringing scale factor which is equal to or greater than one. Equation (1) does not account for the case where multiple materials possessing different relative permittivity

values are in contact with the electrodes. It also assumes that the capacitance between the ends of the teeth and the arms to which the opposite electrode teeth are physically attached is negligible. If the height of the teeth is on the same order as the separation distance, much of the capacitance will be due to the fringing fields outside of the space directly between the interdigitated teeth and γ will be significantly greater than one.

III. FINITE ELEMENT SIMULATION

A finite element is used as the basis for the simulations that solve the Maxwell equation ($\nabla \cdot D = \rho_f$) subjected to the appropriate electromagnetic boundary condition. The classic electrostatic boundary conditions are assumed as the tangential component of the electric field across dielectric interface is continuous ($E_{t1} = E_{t2}$) and the normal component of the electric flux density is continuous at the surface ($D_{n1} = D_{n2}$) from the Maxwell equation of

$$\nabla \cdot D = \rho_f \quad (2)$$

$$D = \epsilon E \quad (3)$$

$$E = -\nabla \phi \quad (4)$$

where ρ_f is free charge density, D is electric flux density, E is the electric field intensity and ϕ is electric potential.

A two dimensional finite element analysis (FEA) simulation was conducted to examine the degree of field fringing that occurs in the vicinity of the electrode-surface region. The finite element simulation was performed in 3D or 2D depending on the application specific. The cross-sectional area of the sensor arm is invariant with length, thereby reducing the problem to a 2D solution of the Laplace equation.

$$\nabla^2 V = 0 \quad (5)$$

where V is the electric potential. Galerkin's method was employed for the numerical solution to the hyperbolic problem using standard six-node triangles. In the solution, the algebraic equations were solved using Gaussian elimination. All conducting surfaces were approximated as perfect electric conductors, and the continuity of the normal component of the electric flux density ($D = \epsilon E$) maintained at the dielectric-air interface

$$\sum_1 \frac{\partial V}{\partial n} = \sum_2 \frac{\partial V}{\partial n} \quad (6)$$

where n is the unit vector perpendicular to the dielectric-air interface.

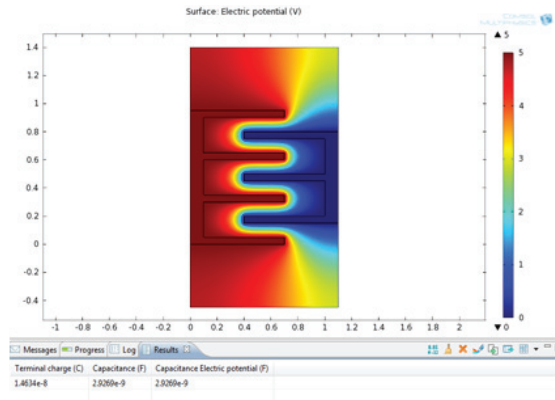

Fig. 3 Finite element simulation of IDE sensor

Here interdigitated electrode structure is used as sensor which is developed using finite element simulation. In FEM, one sensor arm is given as the required voltage and other sensor arm is to be grounded. This differential voltage produces the capacitance value by changing the permittivity. The capacitance value is calibrated between air and water with same material. Similarly, since water has an ϵ_r value approximately 80 times greater than that of air, the water content of many common materials into which the sensor is fully submerged may be estimated.

IV. INTERFACE CIRCUIT

A. Push-Pull Capacitive Sensor

A differential capacitive sensor has two sensing capacitances C_S and C_R whose values change in proportion to the parameter being sensed, and the changes in C_S and C_R are normally equal and opposite. Since the value of one of the capacitances increases and that of the second capacitance kept constant being sensed, differential capacitive sensors are also popularly known as push-pull-type capacitive sensors.

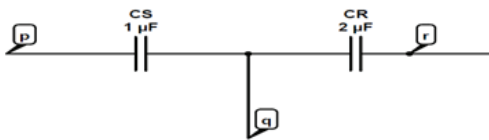

Fig. 4 Differential capacitive sensor

A simplified electrical equivalent circuit of a typical differential capacitive sensor is shown in Fig. 4. If the parameter being sensed alters the area between the plates of the sensor, then such a capacitive sensor will possess a linear input-output relationship, as given by the following

$$C_s = C_0 (1 \pm kx) \tag{7}$$

Here, k is the transformation constant of the sensor, and C_0 is the nominal value of C_1 and C_2 , when x , which is the physical quantity being sensed, is zero. The switched capacitor dual slope capacitance to digital converter is based on differential capacitive sensor.

V. SWITCHED CAPACITOR DSCDC

The functional block diagram of the proposed DSCDC is shown in Fig. 4. As in any dual-slope technique, the DSCDC is made of an switch, integrator and a comparator. As indicated in Fig. 4, the sensor capacitance C_S and C_R in combination with three single-pole double-throw (SPDT) switches SW1, SW2, and SW3, opamp and the feedback capacitor C_f form a switched-capacitor integrator. The status of the output of the integrator is sensed by the comparator.

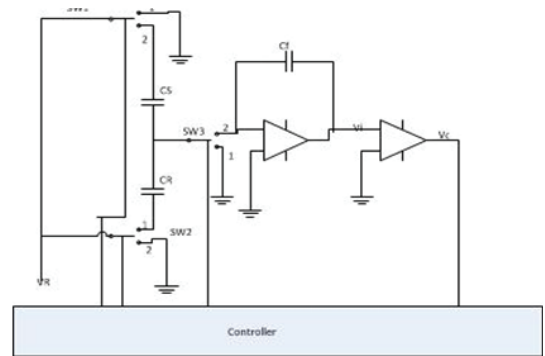

Fig. 5 Block diagram of DSCDC

VI. CONVERSION CYCLE

A typical conversion cycle consists of two time periods, which is T_1 and T_2 . While the period T_1 is a preset value, T_2 is measured. During T_1 , when the clock is high ($TC/2$), switch SW2 is set at position 2, and switches SW1 and SW3 are set to position 1. When the clock turns low, switch SW2 is changed to position 1, and SW1 and SW3 are set to position 2. Thus, whenever the clock is high, C_S will charge to V_R , and C_R will get discharged to ground. As soon as the clock goes low, the charge in C_S will be transferred to C_f , and at the same time, the charging current of C_R is also sent into C_f . Hence, the differential charge between V_{RCS} and V_{RCR} , i.e., $V_R (C_S - C_R)$, will get transferred to C_f for every clock cycle. If $C_S > C_R$, then V_i ramps in the positive direction in steps of value $V_R (C_S - C_R)/C_f$ for every clock period TC , as indicated by the solid line in Fig. 6. On the other hand, if $C_R > C_S$, then v_{oi} will ramp in the negative direction in steps

of value $VR (CR-CS)/CF$ for every clock, as indicated by the dotted line in Fig. 6. If $CS = CR$, then the differential charge transferred to CF for every clock is zero; hence, at the end of $T1 (= N1TC, \text{ with } N1 \text{ being a preset integer})$, the output of integrator V_i will remain zero.

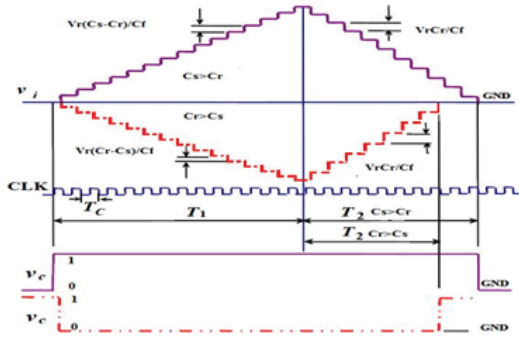

Fig. 6 Integrator output and comparator output

The second integration period $T2$ commences as soon as the period $T1$ is completed. If V_c is high at the end of $T1$ (i.e., $CS > CR$), then switches $SW1$ and $SW3$ to position 2 and $SW2$ to position 1 whenever the clock is high and whenever clock is low, $SW1$ to position 2, $SW2$ to 2 & $SW3$ to position 1 is connected. Thus, when the clock is high, CR will get charged to VR , and their charging current will discharge CF by $VR(CR)/CF$. When the clock goes low, both sensor capacitances and reference capacitance are discharged to ground. This process is repeated for every clock cycle.

Hence, the output of the integrator gradually decreases in steps of $VR (CR)/CF$ and reaches zero. On the other hand, if V_c is low at the end of $T1$ (i.e., $CR > CS$), then switches $SW2$ and $SW3$ switched to position 1 and $SW1$ switched to position 2 whenever the clock is high, both CR will get charged to VR . In addition, when the clock goes low, their net charge $VR(CR)$ is transferred to CF , discharging it. Under this condition, V_i increases in steps of $VR (CR)/CF$ and reaches zero, as indicated by the dotted line in Fig. 6. A flowchart showing the sequence of operations and switch positions during the periods $T1$ and $T2$, depending on the comparator output voltage V_c , is shown in Fig. 7.

At the end of period $T2$, the net charge in CF is zero. As per the equation $C_s = C_0 (1 \pm kx)$, set $CR=C_0$, Then $T2$ will become,

$$\frac{T_2}{T_1} = \frac{C_0(1 \pm kx) - C_0}{C_0} \tag{8}$$

which is equal to $\pm kx$. We know $N_2 = \frac{T_2}{T_c}$ and $N_1 = \frac{T_1}{T_c}$ then

$$\frac{N_2}{N_1} = \frac{T_2}{T_1} = \pm kx \tag{9}$$

$N1$ is the preset value from $T1$ and we can calculate the digital value from known value of $N1, T1$ and integration value. The following graph shows the response of dual slope converter. Since $N1$ is a preset value and k is the sensor's transformation constant, the digital value $N2$ directly represents the quantity x being sensed by the sensor. Thus, the technique presented here implements a linear direct CDC applicable for not only differential capacitive sensors possessing linear characteristics but also sensors possessing inverse characteristics without any change.

VII. SIMULATION RESULT

A. Capacitance Measurement

The sensor capacitance is measured by using COMSOL tool. COMSOL tool is mainly based on Maxwell equation. Finite element method is used to determine the capacitance. COMSOL is one of the tool using finite element method. It gives the output either in 2D or 3D. COMSOL Multiphysics is an interactive engineering and physics tool that performs equation based modelling in a visual interface. This software allows the modelling and simulation of any physical

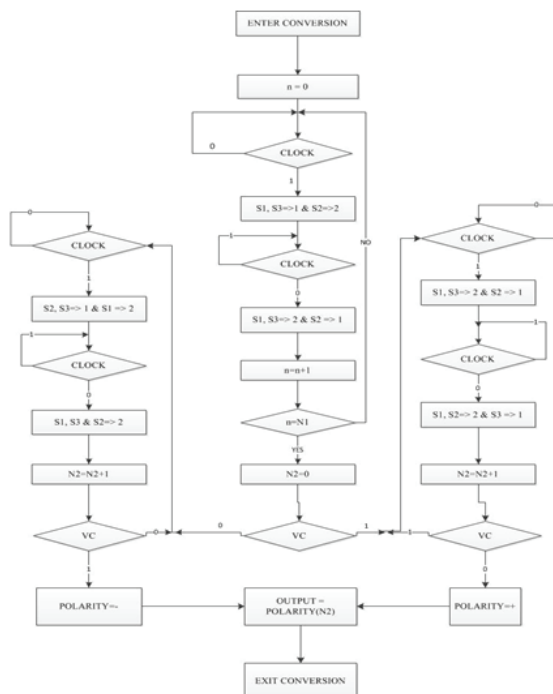

Fig. 7 Flowcharts for conversion cycle

phenomena in a way that's easy to implement. It comes preinstalled with different model libraries that can be readily used. Some of the libraries include modules such as Chemical Engineering Modules, MEMS Modules, RF Modules and Structural Mechanics Module.

Electrostatics part of MEMS module is used in 3D. 3D electrostatics problem by first creating a 2D geometry using the array tools and then extrude it to a 3D geometry, perform Mesh analysis and compute the capacitance using the Electrostatics application mode's port boundary condition. The simulation result and its corresponding capacitance value using COMSOL software is shown below in figure 8 and Table I.

TABLE I CAPACITANCE VALUE FOR DIFFERENT PERMITTIVITY VALUE

Permittivity(ϵ)	$C_{capacitance}$ (F)	Ch_{ϵ} e(Q)
1 (Air)	9.9578e-14	4.9789e-13
2	1.9916e-13	9.9578e-13
3	2.9873e-13	1.4937e-12
4	3.9831e-13	1.9916e-12
5	4.9789e-13	2.4895e-12
6	5.9747e-13	2.9873e-12
80(Water)	7.9663e-12	3.9831e-11

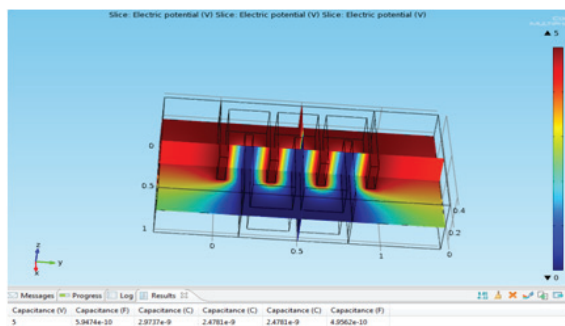

Fig. 8 Charge variation using COMSOL

VIII. INTERFACE CIRCUIT

The capacitance mentioned in the above table is measured digitally. It can be performed by using analog to digital converter. Here dual slope type of ADC is used. Digital representation corresponds to difference in sensor capacitance and reference capacitance. The clock signal and square wave pulse is used to control the switches. It is simulated using SPICE software and the response is obtained. The modified output is shown in Figure 9.

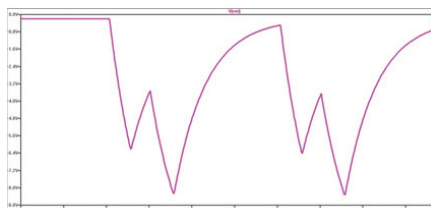

Fig. 9 Output from SPICE

VI. CONCLUSION

Capacitive sensors have been utilized for the detection or measurement of water content. Most of these sensors utilize some type of interdigitated electrode structure. Low-cost capacitive fringing field sensor technology based on standard PCB technology has to be developed. Capacitance is found by using this technology is lesser in comparison to the other technology. At low cost and low frequency, the proposed sensor has been developed. Conversion time is good as a typical dual slope ADC and the proposed technique has high accuracy. The sensor capacitances become an integral part of a dual-slope converter, and the converter logic has been chosen, such that it provides a digital output directly proportional to the parameter being sensed by the sensor.

REFERENCES

- [1] F. Attivissimo, G. Cannazza, A. Cataldo, E. De Benedetto, and L. Fabbiano, "Enhancement and etrological characterization of an accurate and low-cost method based on seismic wave propagation for soil moisture evaluation," *IEEE Trans. Instrum. Meas.*, Vol. 59, No. 5, pp. 1216–1223, May 2010.
- [2] Cataldo, G. Monti, E. De Benedetto, G. Cannazza, and L. Tarricone, "A noninvasive resonance-based method for moisture content evaluation through microstrip antennas," *IEEE Trans. Instrum. Meas.*, Vol. 58, No. 5, pp. 1420–1426, May 2009.
- [3] J. L. Davis and A. P. Annan, "Ground penetrating radar to measure soil water content," in *Methods of Soil Analysis*, J. H. Dane and G. C. Topp, Eds. Madison, WI: SSSA Inc., 2002, ser. 5, pp. 446–463.
- [4] T. J. Jackson, "Measuring surface soil moisture using passive microwave remote sensing," *Hydrol. Processes*, Vol. 7, No. 2, pp. 139–152, Apr.–Jun. 1993.
- [5] Robert Neal Dean, Aditi Kiran Rane, Michael E.Baginski, Jonathan Richard, Zane Hartzog, and David J. Elton, "A Capacitive Fringing Field Sensor Design for Moisture Measurement Based on Printed Circuit Board Technology," *IEEE transactions on instrumentation and measurement*, Vol. 61, No. 4, April 2012.
- [6] Bobby George and V. Jagadeesh Kumar, "Analysis of the Switched-Capacitor Dual-Slope Capacitance-to-Digital Converter", *IEEE transactions on instrumentation and measurement*, Vol. 59, No. 5, May 2010.
- [7] K. Kazuyuki and K. Watanabe, "An auto ranging switched-capacitor analog-to-digital converter," *IEEE Trans. Instrum. Meas.*, Vol. IM-36, No. 4, pp. 879–881, Dec. 1987.
- [8] George and V. J. Kumar, "Novel switched-capacitor dual slope capacitance to digital converter for differential capacitive sensors," in *Proc IEEE I2MTC*, Singapore, May 2009, pp. 1–4.
- [9] J.M. G. Cama, S. A. Bota, E. Montane, and J. Samitier, "AMOSFET-only second order Delta-Sigma modulator for capacitive sensors interfaces," in *Proc. IEEE ICECS*, Pafos, Cyprus, Sep. 1999, pp. 1689–1692.
- [10] B. Wang, T. Kajita, T. Sun, and G. Temes, "High accuracy circuits for onchip capacitance ratio testing and sensor readout," *IEEE Trans. Instrum. Meas.*, Vol. 47, No. 1, pp. 16–20, Feb. 1998.