

# Experimental Investigations on Finding Ball Bearing Defects Using Signature Analysis

K.Gunasekar<sup>1</sup> and A.Pugazhenth<sup>2</sup>

<sup>1</sup>Assistant Professor, Department of Mechanical Engineering,

PSNA College of Engineering and Technology, Dindigul, Tamil Nadu, India

<sup>2</sup>Assistant Professor, Department of Mechanical Engineering Anna University,  
University College of Engineering. Dindigul. Tamil Nadu, India

E-mail: gunasekark17@gmail.com

(Received 11 May 2014; Accepted 28 June 2014; Available online 6 July 2014)

**Abstract** - This paper presents for identify the defected bearing using vibration frequency. There have been a lot of researches on diagnosing rolling element bearing faults using wavelet analysis, but almost all methods are not ideal for picking up fault signal characteristics under strong noise. The rolling element bearing is used widely in all rotating components. It is one of the most susceptible components in a machine because it is most often under maximum load and high speed running conditions. This paper describes the suitability of vibration monitoring and analysis techniques to become aware of defects in antifriction bearings. Time domain analysis, frequency domain analysis and spike energy analysis have been working to identify different defects in bearings.

**Keywords:** Signal characteristics, Time domain analysis, and frequency domain analysis.

## Notation

BD, PD	: roller diameter and pitch d respectively, mm
$f_o, f_i, f_r$	: outer race, inner race and malfunction frequencies, r respectively, H
$f_r$	: rotational frequency, Hz
$n$	: number of rollers
$b$	: angle of contact

## I. INTRODUCTION

Bearings are what enable things to roll. Without bearings our industrial world would, in many respects, stand still. The first bearing with the help of the wheel enabled people to move themselves and their goods from one village to another. It helped them in producing their food. Today, bearing technology has developed to a stage where bearings are one of the most advanced mechanical components with regard to optimized design, high quality materials and accurate manufacturing. Condition monitoring of antifriction bearings in rotating machinery using vibration analysis is a very well established method. It offers the advantages of reducing down time and improving maintenance efficiency. The machine need not be stopped for diagnosis. Even new or geometrically perfect bearings may generate vibration due to contact forces, which exist between the various components of bearings. Antifriction bearing defects may be categorized as localized and dispersed. The localized defects include cracks, pits and spalls caused by fatigue on rolling surfaces. The other category, *ie*, distributed defects includes surface roughness, waviness, and misaligned races and off size rolling

elements. These defects may result from manufacturing error and abrasive wear. Hence, study of vibrations generated by these defects is important for quality inspection as well as for condition monitoring. Antifriction bearing failures result in serious problems, mainly in places where machines are rotating at constant and high speeds. In order to prevent any terrible consequences caused by a bearing failure, bearing condition monitoring techniques, such as, temperature monitoring, wear debris analysis, oil analysis, vibration analysis and acoustic emission analysis have been developed to identify life of flaws in running bearings. Among them vibration analysis is most generally accepted technique due to its easiness of application.

Vibration signature monitoring and analysis in one of the main techniques used to predict and diagnose various defects in antifriction bearings. Vibration signature analysis provides early information about progressing malfunctions and forms the basic reference signature or base line signature for future monitoring purpose. Defective rolling elements in antifriction bearings generate vibration frequencies at rotational speed of each bearing component and rotational frequencies are related to the motion of rolling elements, cage and races. Initiation and progression of flaws on antifriction bearing generate specific and predictable characteristic of vibration. Components flaws (inner race, outer race and rolling elements) generate specific defect frequencies calculated.

The time domain and frequency domain analyses are widely accepted for detecting malfunctions in bearings. The frequency domain spectrum is more useful since it also identifies the exact nature of defect in the bearings. Spike energy analysis makes use of spike energy meter to measure three parameters of high frequency pulses, namely, pulse amplified, pulse rate and high frequency 'random vibratory energy' associated with bearing defects.

## II. EXPERIMENTAL SETUP

An experimental test rig built to predict defects in antifriction bearings is shown in Figure 1. The test rig consists of a shaft with central rotor, which is supported on two bearings. An induction motor coupled by a flexible coupling drives the shaft. Self aligning double row ball bearing is mounted at driver end and cylindrical roller bearing is mounted at free end. The cylindrical roller

bearing is tested at constant speed of 1400 rpm with radial load of 230 N. Cylindrical roller bearing type NRB NU 305 (with outer race and roller defects), HMT e-245 (with inner race defect) have been used for analysis.

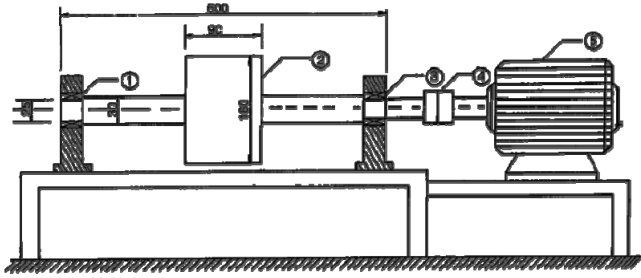

Fig.1 Basic Experimental Setup

1-roller bearing; 2-rotor; 3-self aligning ball bearing; 4-flexible

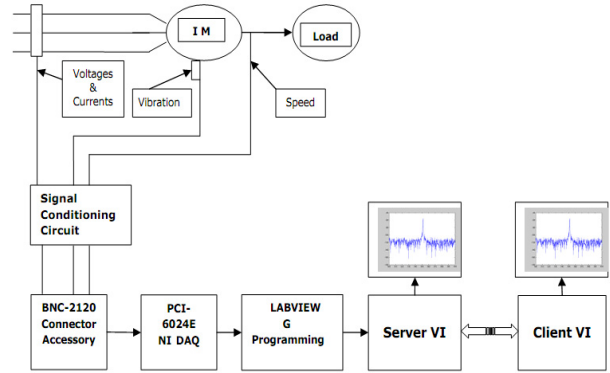

Fig.2 Basic Schematic Diagram of Remote Monitoring System

**III.DEVELOPMENT OF MONITORING System**

Parameter	Value
Number of rollers	10
Outer diameter, mm	62
Inner diameter, mm	25
Pitch diameter, mm	44
Roller diameter, mm	8
Contact angle, b	0

The details of the bearings used in the present analysis are given in table 1. provision is made on the roller bearing coupling and 5-motors.

The basic functions of monitoring system are sensing, signal conditioning, data acquisition and signal processing. Each function has many parameters with different specifications. In the present work, the monitoring system uses motor current and vibration parameters to determine the machine condition. The selection of the sensing elements depends on the limit of changes of the machine variables, desired accuracy and the monitoring method. Machine variables such as three phase stator currents in the case of induction motor, speed, vibration (radial and horizontal) that cover the entire requirement to recognize the expected types of faults, are selected for monitoring. Speed sensor, piezoelectric accelerometer and ac current clamps are used to measure the mentioned machine variables.

Most of the sensors provide outputs in the form of electrical signals (digital or analog) and the level of the output and the linearity with the input needs to be conditioned. A signal conditioning circuit is developed to make the signal levels compatible with the NIDAQ 6024E. In the present work the analog signals are transferred to data acquisition card(NIDAQ 6024E) through BNC-2120 connector (Fig. 2). The speed of data acquisition system and the number of inputs to be scanned are controlled by the LabVIEW software.



Fig.3 Test Setup

**IV.RESULTS AND DISCUSSION**

The vibration signals of good bearing and defective bearing is shown in Figures 4 and 5, respectively. The magnitude of peak to peak time response of good bearing is found to be in the 10 mV range in comparison to 200 mV range for defective bearings. In order to assess the clarity in different defects in bearings the spectrum analysis is shown in Figures 4-6 for good bearing, bearing with inner race defect, bearing with outer race defect and bearing with roller defect, respectively. The details of inner race defect, outer race defect and roller defect are shown in Figures 4-6, respectively. The magnitude of spectrum at various harmonic frequencies for defective bearing is found to be quite distinct in comparison to good bearings. The frequency spectrum of the vibration signal from the inner race defect bearing shows the peaks at 137 Hz, 275 Hz, 413 Hz, 551 Hz and 827 Hz. The fundamental frequency estimated for the inner race defect is found to be 137.85 Hz. The frequency spectrum of the vibration signal from outer race defect shows the peaks at 95 Hz, 190 Hz, 286 Hz, 477 Hz, 668 Hz, 763 Hz and 950 Hz. The fundamental frequency for the outer race defect bearing is found to be 95.44 Hz.

The frequency spectrum of the vibration signal from the roller defect bearing shows the peaks at 81 Hz, 163 Hz, 244

Hz and 326 Hz, 408 Hz, 489 Hz, 571 Hz, 653 Hz and 698 Hz. The fundamental frequency for the roller defect bearing is found to be 81.65 Hz. The results correlate very well.

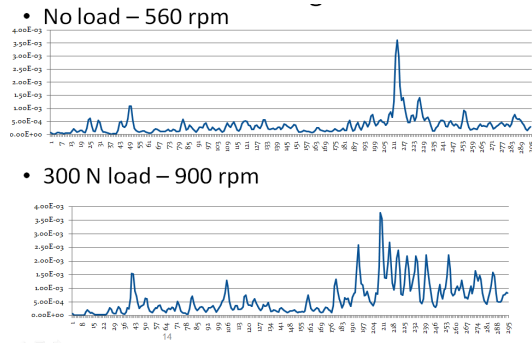

Fig.4 Freq domain Analysis - Healthy Bearing

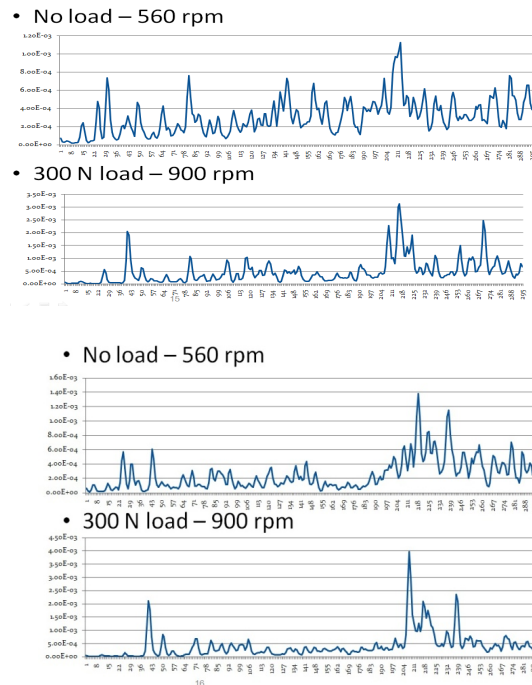

Fig.5 Freq Domain Analysis – Inner Race Ball fault

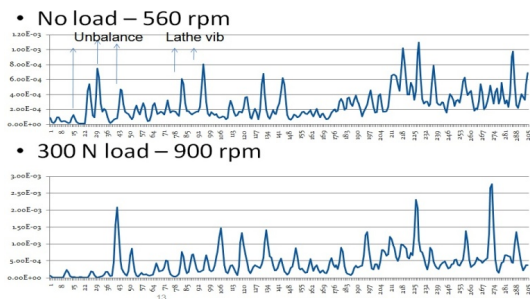

Fig.6 Ball Bearing-Freq Domain Analysis - Ball Fault

## V.CONCLUSIONS

Time waveform and frequency spectrum provide useful information to enable to predict presence of defects on inner race, outer race analyze defects in antifriction bearings. Time waveform indicates severity of vibration in

defective bearings. Frequency domain spectrum identifies amplitudes corresponding to defect frequencies and rollers of antifriction bearings. Spike energy factor helps to identify the severity of the defect in antifriction bearings. The distinct and different behavior of vibration signals from bearings with inner race defect, outer race defect and roller defect helps in identifying the defects in roller bearings.

## REFERENCES

- [1] Dr. S. J. Lacey "An Overview of Bearing Vibration Analysis," Engineering Manager Schaeffler UK Limited.
- [2] Ronald N. Bracewell "Waveform Analysis Using The Fourier Transform," *Scientific American*, June 1989, pp. 86-95.
- [3] YDr. S. J. Lacey "An Overview of Bearing Vibration Analysis," Engineering Manager Schaeffler UK Limited.
- [4] Arul Muthukumarasamy, Suri Ganeriwala "The Effect of Frequency Resolution in Bearing Fault Studies," *Technote, SpectraQuest Inc.*, (Feb 2010).
- [5] S. A. McNerny and Y. Dai "Basic Vibration Signal Processing for Bearing Fault Detection," *IEEE Transactions On Education*, Vol. 46, No. 1, February 2003.
- [6] Alan Friedman "Demodulation technique for vibration analysis," 253 Winslow Way West, Bainbridge Island, WA.
- [7] Alan Friedman – DLI Engineering "Bearing vibration condition monitoring of motor coupled pump,"
- [8] D. Ganeshkumar and K. Krishnaswamy "Intelligent bearing tester using labview," *Jl. of Instrum. Soc. of India*, Vol. 39 No. 1, March 2009.
- [9] S B Khandagal and R Shrinidhi "Prediction of Defects in Antifriction Bearings using Vibration Signal Analysis," *IE (I) Journal-MC*, Vol 84, July 2004.
- [10] Dr. S. P. Gupta "Remote condition monitoring of electric motors using labview," *xxxii national systems conference*, NSC 2008, December 17-19, 2008
- [11] Sanjeev Kumar & Rupinder Singh (2010) "A LABVIEW mini-expert to identify bearing defects automatically," *National system conference*, Vol. 50:625–633.
- [12] Ahmed A. Elfeky, Mahmoud I. Masoud, Ibmhim F. El-Arabawy (SMIEEE) "Fault Signature Production for Rolling Element Bearings in Induction Motor," 1-4244-1055-X/07©2007 IEEE.