

Design of Milling Fixture in Mass Production of Pivot Block

Rajkumar.D.Patil¹, Dothre Dinesh², Hegade Sachin³, Urane Vivek⁴ and Killedar Vishal⁵

¹Assistant Professor, Mechanical Engineering,

^{2,3,4,5}UG Student, Mechanical Engineering,

DKTE's Textile and Engineering Institute, Ichalkaranji, Maharashtra, India

E-mail: rajsidhant13909@gmail.com

Abstract - Fixtures are essential elements of production processes as they are required in most of the automated manufacturing, inspection, and assembly operations. Mass production methods demand a fast and easy method of positioning work for accurate operations on it. Jigs and fixtures are production tools used to accurately manufacture duplicate and interchangeable parts.

This paper aims at the Design of milling fixture using CATIA software. A milling fixture is used to hold and support the work piece in proper position during the milling operation. It is the manually operated simple milling fixture. Use of this milling fixture causes ease in operation, cost reduction, easy maintenance and replacement. In today's fast growing industrial sector this milling fixture plays very important role by saving time to achieve quality work pieces and components.

Keywords: Milling fixture, mass production, CATIA, fixture plate, 3-2-1 principle.

I. INTRODUCTION

Fixture is a device for locating, holding, and supporting a work piece during a manufacturing operation. Fixtures are mostly designed for a definite operation to process a specific work piece. They are designed and manufactured individually. Fixtures are used to produce duplicate parts accurately. In order to produce parts in precise manner the parts must be firmly and perfectly fixed to the fixture. To do this a fixture is designed and built to hold support and locate the work piece to ensure the work piece is machined within the specified limits.

Set blocks, fillers or thickness gauges are used in the fixture to refer the work piece with the cutter tool. A fixture should be correctly tightened to the worktable upon which the work is to be done. The design of fixture varies based on the use of relatively simple tools to expensive or complicated devices. Fixtures simplify the working operation performed on the special components. In fixture for supporting and clamping the work piece, locators, clamps and support plates are provided. Frequent checking, positioning, individual marking and changing in quality in manufacturing process is eliminated by fixture. Use of milling fixture increases productivity and reduce operation time. [2]

A.Fundamental Principles of Jigs and Fixtures Design

Locating points: Good facilities should be provided for locating the work. The article to be machined must be easily

inserted and quickly taken out from the jig so that no time is wasted in placing the work piece in position to perform operations. The position of work piece should be accurate with respect to tool guiding in the jig or setting elements in fixture. [5]

Fool proof: The design of jigs and fixtures should be such that it would not permit work piece or the tool to insert in any position other than the correct one. [5]

Reduction of idle time: Design of Jigs and Fixtures should be such that the process, loading, clamping and unloading time of the work piece takes minimum as far as possible.

Weight of jigs and fixtures: It should be easy to handle, smaller in size and low cost in regard to amount of material used without sacrificing rigidity and stiffness.

Jigs provided with feet: Jigs sometimes are provided with feet so that it can be placed on the table of the machine.

Clamping device: It should be as simple as possible without sacrificing effectiveness. The strength of clamp should be such that not only to hold the work piece firmly in place but also to take the strain of the cutting tool without springing when designing the jigs and fixtures.

B.Essential Features of Jigs and Fixtures

Reduction of idle time: It should be enable easy clamping and unloading such that idle time is minimum.

Cleanliness of machining process: Design must be such that not much time is wasted in cleaning of scarfs, burrs, chips etc.

Replaceable part or standardization: The locating and supporting surfaces as far as possible should be replaceable, should be standardized so that their interchangeable manufacture is possible.

Provision for coolant: Provision should be there so that the tool is cooled and the swarfs and chips are washed away.

Inserts and pads: These should always be riveted to those faces of the clamps which will come in contact with

finished surfaces of the work piece so that they are not spoilt.

Economic soundness: Equipment should be economically sound, cost of design and manufacture should be in proportion to the quantity and price of producer.

Easy manipulation: It should be as light in weight as possible and easy to handle so that workman is not subjected to fatigue, should be provided with adequate lift aids

Initial location: It should be ensured that work piece is not located on more than 3 points in anyone plane test to avoid rocking, spring loading should be done.

Position of clamps: Clamping should occur directly above the points supporting the work piece to avoid distortion and springing.

Clearance: Sufficient amount of clearance should be provided around the work so that operator's hands can easily enter the body for placing the work piece and any variations of work can be accommodated.

Rigidity and stability: It should remain perfectly rigid and stable during operation. Provision should be made for proper positioning and rigidly holding the jigs and fixtures.

Safety: The design should assure perfect safety of the operator. [5]

C. Materials Used for Jigs and Fixtures

- a. High speed steel
- b. Die steels
- c. Carbon steels
- d. Collet steels
- e. Non shrinking tool steels
- f. Nickel chrome steels
- g. High tensile steels
- h. Mild steel
- i. Cast iron

D. Factors to be Considered for Design of Jigs and Fixtures

Component: Drawing of the component to be studied carefully. Ensure work is performed in a proper sequence. Maximum operations should be performed on a machine in single setting.

Capacity of the machine: Careful consideration to be performed on type and capacity of machine.

Production requirements: Design to be made on basis of actual production requirements. Then comes decision on manual and automatic tooling arrangements.

Location: Location should ensure equal distribution of forces throughout all sequence of operation. Location should be hard resistant, wear resistant and high degree of accuracy. Movement of work piece should be restricted. We should be fool proofed to avoid improper locations of the work piece. We should facilitate easy and quick loading of work piece. Redundant locators should be avoided. Sharp corners must be avoided. At least one datum surface should be established.

Loading and unloading arrangements: There should be adequate clearance for loading and unloading. Hence process becomes quick and easy. Size variation must be accepted. It should be hardened material and non-sticky.

Clamping arrangements: Quick acting clamps must be used as far as possible. The clamping should not cause any deformation to the work piece. It should always be arranged directly above points supporting the work. Power driven clamps are favored as they are quick acting, controllable, reliable and operated without causing any fatigue to the operators.

Base and Body construction: Methods used: Machining, Forging and machining, Casting, Fabricating, Welding.

Tool guiding and cutter setting: By adjusting the machine or using cutter setting block, the cutter is set relative to the work in a fixture. The drill bushes fitted on jig plates guides the tools.

Rigidity and vibration: fixture must possess enough rigidity and robustness. Should not vibrate as it may lead to unwanted movement of work piece and tools.

Safety: Operation should be assured full safety.

Cost: Cost incurred should be optimum. [5]

II. PROBLEM DEFINITION

While milling operation on pivot block as shown in figure 1, various problems are occurred. The machining accuracy of pivot block a major issue during milling operation. The pivot block require milling operation inclined at 12 degrees to the horizontal axis. Milling at 12° will be too difficult to manufacture pivot block with precision. This situation requires a milling fixture to manufacture pivot block with reduction in operation time.

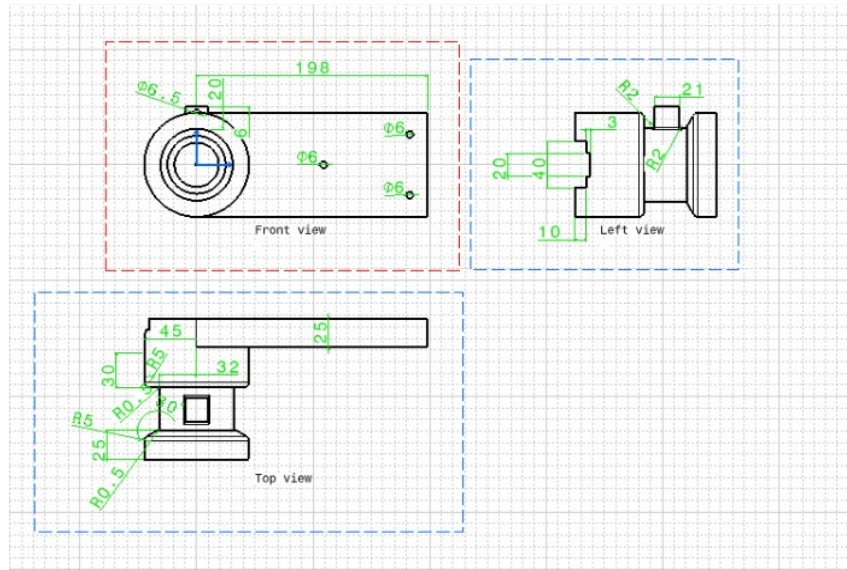

Fig.1 2D Drawing Of Pivot Block

Figure 2, shows 3D model of pivot block on which milling operation at 12° is to be done.

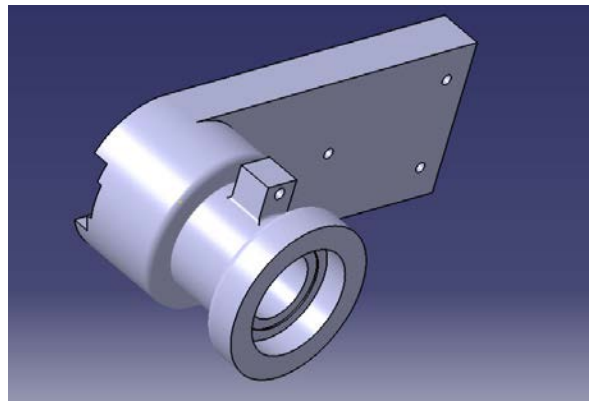

Fig.2 3d model of pivot block

III. METHODOLOGY

Steps Followed to Solve the Problem

1. Problem definition: The milling operation is to be performed in 12 degrees from the center line as shown in figure 1. This milling operation is complicated because clamping of job is difficult.
2. Study of alternative methods for solving problem: The fixture is to be designed by using CAD (computer aided drafting) and CATIA (computer aided 3 dimensional interactive application).
3. Proper selection of method: CATIA is selected for designing of fixture because of its simplicity of drawing.
4. Cad modeling: Designing fixture by using CATIA.

IV. DESIGN CONSIDERATION FOR FIXTURE

3-2-1 Principle of Fixture Designing: For a fixture design the major portion of design time is spent deciding how to locate the work piece in fixture. We know that any free body has a total of 12 degree of freedom. 6 translational degree of freedom +X, -X, +Y, -Y, +Z, -Z. [1]

1. Clockwise around X axis
2. Anticlockwise around X axis
3. Clockwise around Y axis
4. Anticlockwise around Y axis
5. Clockwise around Z axis
6. Anticlockwise around Z axis

From these 12 degrees of freedom 9 degrees of freedom should be restricted, rest 3 degrees of freedom should be keep free for loading and unloading of job.

V. DESIGN OF MILLING FIXTURE

The milling fixture includes various parts as follows:

1. Fixture plate 2.C washer 3.Arbor 4.Support washer 5.Height bar 6.bolt .These parts are manufactured according to various considerations like force exerted on the fixture and the clamping force requirement. The parts dimensions are decided according to design considerations and consulting with industry experts. The detailed drawing of each part is given below:

1.Fixture Plate: Fixture plate is the main component of this milling fixture. The whole assembly of the fixture is fitted on the fixture plate. The weight of fixture plate is more to possess high damping capacity. The figure 3 shows 2D drawing of milling fixture plate and Figure 4 shows 3D model of milling fixture plate.

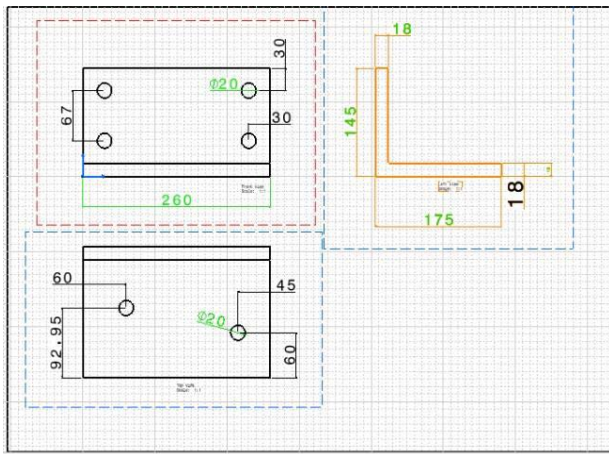

Fig.3 2D drawing of fixture plate

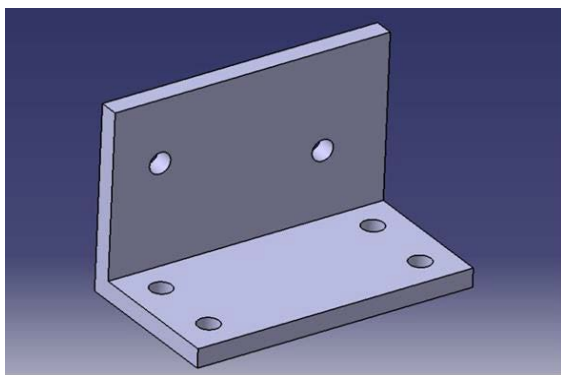

Fig.4 3D model of fixture plate

2.C Washer: C washer is mainly used for clamping the job on the arbor. The main purpose of the c washer is to hold the job. It also supports the M20 bolt. The slot is provided at the center for ease removal. Figure 5 and 6 shows the 2D and 3D drawing of C washer respectively.

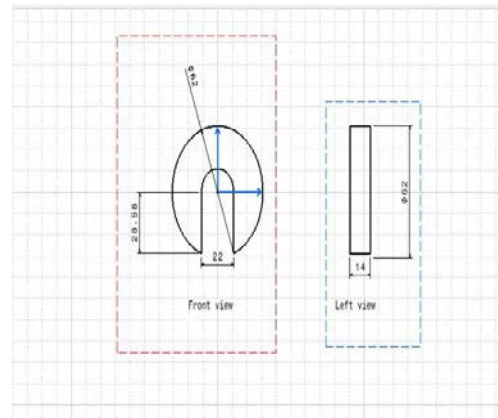

Fig.5 2D drawing C washer

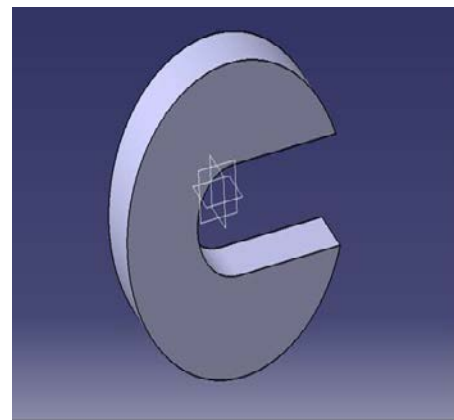

Fig.6 3D model of C washer

3.Arbor: The main function of arbor is to locate the job at preferred position. Arbor supports the job. It holds job at position at the time of operation. Figure 7 and 8 gives 2D and 3D drawing of Arbor

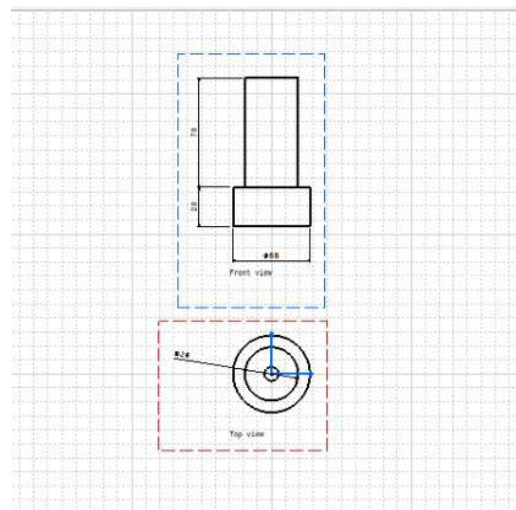

Fig.7 2D drawing of Arbor

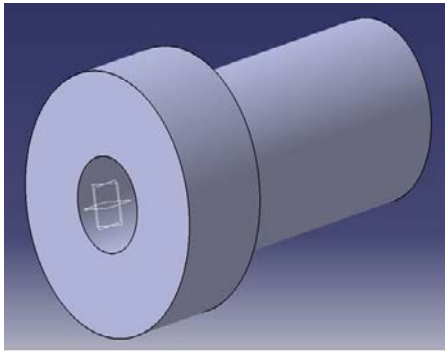

Fig.8 3D model of Arbor

4.Support Washer

Support washer supports the job by putting it into the slot existing in job. Support washer usually have an outer diameter about twice the width of their inner diameter. Figure 9 shows the drawing for support washer.

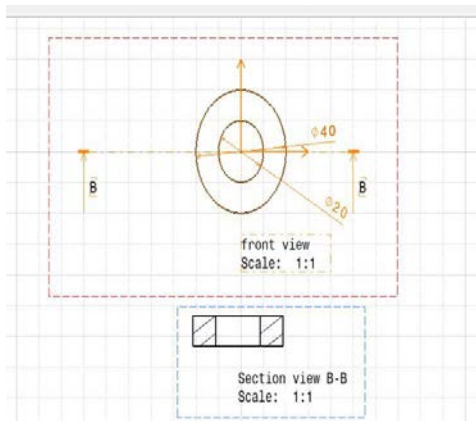

Fig.9 2D drawing of Support washer

5.Height Bar

This height bar is used for distribute the load on the bolt of M20. The outer diameter of this height bar is 30mm. The thickness is 5mm. Surface milling is done at outer diameter of bar for safety purpose during milling operation. Figure 10 shows 2D drawing of Height bar.

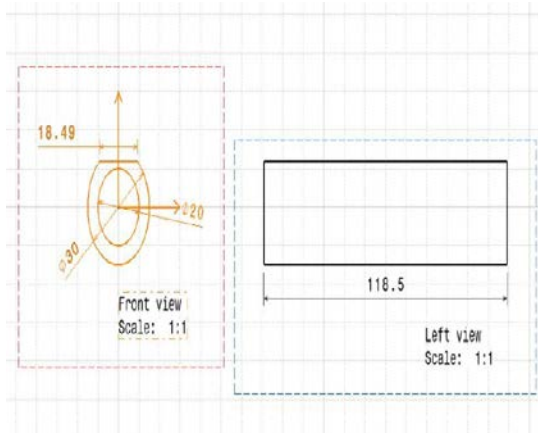

Fig.10 2D drawing of Height bar

6.Bolts

This threaded block is used for tightening of fixture plate and milling machine table. It also used for arbor and height bar mounting. The bolt of ISO 4014 M20x80 steel grade, hexagon head is used. Figure 11 shows 3D drawing of Bolt.

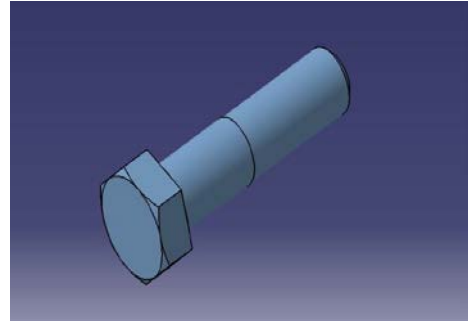

Fig.11 3D model of Bolt

Figure 12 shows the 3D model of assembly of milling fixture for manufacturing pivot block.

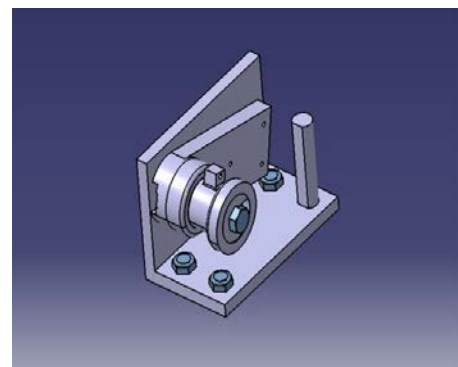

Fig.12 3D model of milling fixture

VI. CONCLUSIONS

The milling operation at 12 degrees was performed at the center line of pivot block with dimensional accuracy by using the designed milling fixture. CATIA can be used effectively for drawing the parts of milling fixture. Loading and unloading of Pivot block became easy during the milling operation. Hence by using this fixture milling operation time was reduced considerably.

REFERENCES

- [1] P. C. Sharma, "Production engineering", S Chand Publications, 2006.
- [2] Shivaji Popat Mengawade, Vaibhav Banker, "Design and analysis of work holding fixture", IJSRD, 2016
- [3] Sanket Prasad, Shinde M, "Review on fixture design and manufacturing", IJSRD, 2016
- [4] A. D. Kachare, G. M. Dahane, "First operation machining fixture", IJEIT, Oct 2012.
- [5] P. H. Joshi, "A textbook of Jigs and fixtures", Tata McGraw Hill Education Pvt. Ltd., New Delhi 110 008.