

Investigating Feed Rate Effect on Cutting Force of EN 8 Turning

Vikas B. Magdum¹ and Vinayak R. Naik²

¹Faculty in Mechanical Engineering,

²Head and Professor of Mechanical Engineering,
D. K. T. E. Society's Textile and Engineering Institute,
Ichakaranji, Kolhapur, Maharashtra, India
Email: vbmagdum@rediffmail.com
vrnaik66@gmail.com

Abstract - This paper deals with the measurement of cutting force components generated in turning for different cutting parameters and different tools having various feed rates while machining EN 8 steel. The feed rates of the tool were changed using selected cutting parameters; thus, the cutting force components were measured. The selected cutting variables and the tools in different feed rates were tested practically under workshop conditions. During the tests, the depth of cut and cutting speed were kept constant and each test was conducted with a sharp tool. Finally, the effects of cutting parameters and feed rates on cutting forces were analyzed. A cylindrical EN8 work piece was turned using Carbide tools for three feed rates (0.065, 0.13 and 0.26 mm/rev). For feed rate angle, keeping the cutting speed (384 rpm.) and depth of cut (1 mm) constant. During the experimentation, the forces were measured using a dynamometer.

The experimental results show that the thrust force (F_t) is greater than the feed force (F_f) irrespective of the feed rates. The cutting forces were found to increase with the increase in feed rate.

Keywords: Rake angle, approaching angle, thrust force, feed force, dynamometer.

I. INTRODUCTION

An increase in productivity requires involvement of all production operations, technical possibility for full use or activation of all the available manufacturing facilities. In order to involve all the technological operations, optimum technological processes, optimum tool selection, optimum combination of tool-workpiece material and determination of optimum cutting variables and tool geometry must be considered. Due to more demanding manufacturing systems, the requirements for reliable technological information have increased. This calls for a reliable analysis in cutting in the cutting zone.

During cutting process, the cutting tool penetrates into the workpiece due to the relative motion between tool and workpiece and the cutting forces are measured on a measuring plane in the system. The cutting forces have been measured by the dynamometer. The cutting force is known to be very sensitive to even the smallest changes in the cutting process, special focus was directed to the selection of the conditions of the tests and experimental methodology. It was observed that the cutting forces are directly depended

on the cutting parameters i.e. cutting speed, feed rate, depth of cut, tool material, geometry and workpiece material type [1]-[5].

When the geometric variables like rake angle changed using selected parameter range, the cutting force component variation generated.

II. LITERATURE REVIEW

In metal removal operations, many researches were carried out in the past and many are continuing for the purpose of decreasing production cost and manufacturing parameters without reducing product quality. Baldoukas et al. [6] experimentally investigated the effect of feed rate and tool rake angle by conducting 24 experiments on AISI 1020 steel and found that main cutting force has an increasing trend with the increasing in feed and a decreasing trend as the rake angle increase. Gunay et al. [7] investigated the effect of rake angle on the main cutting force by conducting experiments on AISI 1040 workpiece material. Experimental results were compared with the Empirical results according to Kienzle approach and found that main cutting force has a decreasing trend as the rake angle increased from negative to positive values. The deviation between empirical approach and experiments was in the order of 10–15%. Saglam, et al. [8] have made a comparison of measured and calculated results of cutting force components and temperature variation generated on the tool tip in turning for different cutting parameters and different tools having various tool geometries while machining AISI 1040 steel hardened at HRC 40. Lalwani et al. [9] investigated the effect of cutting parameters (cutting speed, feed rate and depth of cut) on cutting forces (feed force, thrust force and cutting force) and surface roughness in finish hard turning of MDN250 steel (equivalent to 18Ni(250)) maraging steel) using coated ceramic tool. The results show that cutting forces and surface roughness do not vary much with experimental cutting speed in the range of 55–93 m/min. Fang and Jawahir [10] investigated the effects of workpiece hardness, cutting edge geometry, feed rate, cutting speed and surface roughness on hardened AISI H13 steel bars with CBN tools. The effects of two-factor interactions of the edge geometry and the workpiece

hardness, the edge geometry and the feed rate, and the cutting speed and feed rate also appeared to be important. The cutting forces and temperature contributed in the primary shear, chamfer and sticking, and sliding zones are expressed as a function of unknown shear angle, and known friction constants on the rake face and temperature modified flow stress in each zone^[11,12]. Ernst and Merchant^[13] explained the chip formation process when analyzing the cutting process. Fang and Jawahir^[14] investigated the effects of workpiece hardness, cutting edge geometry, feed rate, cutting speed and surface roughness on hardened AISI H13 steel bars with CBN tools.

Back rake angle: It is the angle between the face of the tool and a line parallel to the base of the tool and measured in a plane (perpendicular) through the side cutting edge.

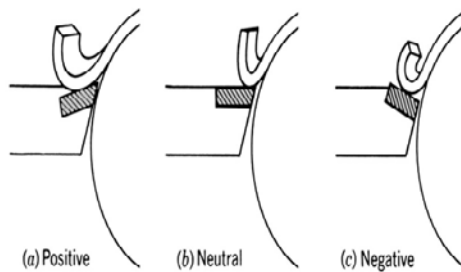

Fig.1 Types of rake angle

This angle is positive; if the side cutting edge slopes downward from the point towards the shank and is negative if the slope of the side cutting edge is reverse also it is neutral if there is no slope of the side cutting edge in upward or downward^[15,16] shown in Fig.1.

The magnitude and direction of cutting forces involved in machining processes help in design and selection of machine tools, cutting tools and accessories. The cutting force and its components generated on the tool point in the turning operation are shown in Fig. 2.

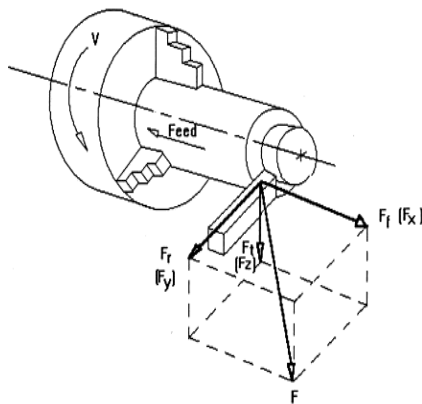

Fig.2 Components of cutting forces

The resultant cutting force F acting in the oblique direction can be resolved along the three perpendicular axes, viz. X, Y and Z. F_t , the thrust or tangential component (shown vertically), determines the torque on the main drive mechanism, the deflection of the tool and the required power. This component acts in the direction of the cutting speed. F_f , the axial component, acts in the direction of the tool traverse and it is at right angles to F_t . It contributes very little to the power consumption. F_r , the radial component, acts along the tool shank and perpendicular to the other two components. It has no share in the power consumption^[17].

In this study, the effect of tool rake angle on cutting force components was investigated. The experiments were carried out on a lathe machine and a dynamometer was used for measuring thrust force (F_t) and feed force (F_f).

III. EXPERIMENTAL SET UP

A.Design of Experiment

An experimental planning was made by using cutting parameters and test conditions that are advised for couple of tool-workpiece. In order to measure cutting forces such as, thrust force (F_t) and feed force (F_f) separately; a dynamometer was used. The dynamometer was equipped with strain gauge so that the thrust and feed component of cutting forces could be measured. The unit consists of a mechanical sensing unit or tool holder and digital force indicator. Force signals coming from dynamometer were measured. The workpiece materials used in the test were selected to represent the major group of workpiece materials used in industry. Special parameter such as the chemical composition is shown in Table 1.

TABLE 1 CHEMICAL COMPOSITION OF EN8

Fe	C	Mn	Si	P	S
98.5	0.4	0.8	0.25	0.015	0.015

For this study, EN8 steel bars were used. After the specimens were cut off in required length, cutting tests were performed on the specimen bars where the diameter was $\Phi 30$ mm and cutting length 100 mm. The experimental set up is shown in Fig.3.

B.Cutting Tool and Cutting Parameter

The cutting tests have been carried out on a lathe machine. By the three different tools designed for different rake angle and approaching angle were used in single point turning operations on EN8 steel. Although the same tools were used in the tests, the approaching angles were obtained by the different as 60° , 75° and 90° ; while the rake angles were changed as 0° , 5° and 10° .

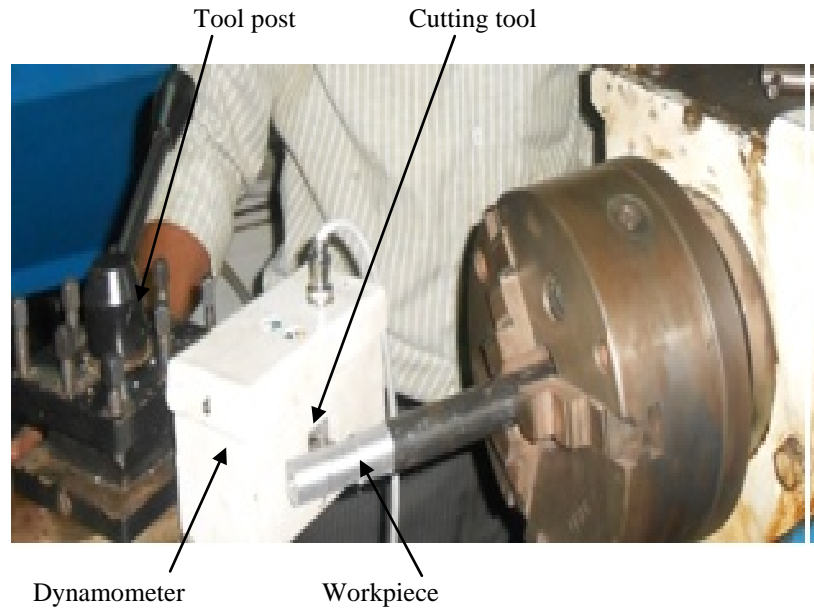

Fig.3 Experimental set-up

C. Cutting Tools

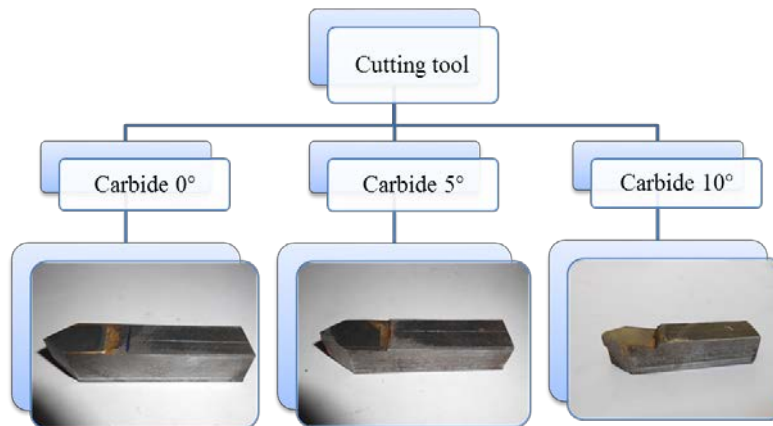

Fig.2 Carbide cutting tools

The cutting parameters feed rate ‘f’ was assigned three different levels varying from 0.065, 0.13 and 0.26 mm/rev, cutting speed ‘v’ and depth of cut ‘d’ were kept constant as 384 rpm and 1mm, respectively. In cutting conditions, small steps were used to increase the reliability of the measured forces. These values are recommended by the cutting tool manufacturer for general purpose and finish turning operations of EN8 steel. Each experiment was carried out with sharp tools in order to keep the cutting conditions unchanged. The tests were conducted in dry conditions and, as a result, totally 15 experiments were performed.

TABLE 2 CUTTING PARAMETER

Cutting speed (rpm)	Depth of cut (mm)	Feed (mm/rev)	Rake angle	Approach angle
384	1.0	0.065	0°	60°
384	1.0	0.13	5°	75°
384	1.0	0.26	10°	90°

In orthogonal cutting, the cutting is assumed as to be uniform along the cutting edge. Rake angle is one of the

most important parameters, which determines the tool and chip contact area. There is generally an optimum value for rake and approaching angle. Increasing rake angle from small values to the optimum value causes reduction in tool/chip contact length; by this, it is expected that the

forces will be reduced. Particularly, negative rake angles cause larger contact area and cause also higher chip volume, both of which lead to increased cutting forces and heat generation. Measured cutting forces and tooltip temperature for various cutting conditions as shown in Table3.

D.Observation Table

TABLE 3 MEASURED CUTTING FORCES FOR VARIOUS CUTTING CONDITIONS

S. No.	Cutting speed (rpm)	Feed (mm/rev)	Depth of cut (mm)	Rake angle (α°)	Approach angle (λ°)	Thrust force (N)	Feed force (N)
1	384	0.065	1	0	60	451	147
2	384	0.13	1	0	60	549	157
3	384	0.26	1	0	60	608	167
4	384	0.065	1	0	75	432	167
5	384	0.13	1	0	75	500	186
6	384	0.26	1	0	75	549	196
7	384	0.065	1	0	90	373	206
8	384	0.13	1	0	90	461	226
9	384	0.26	1	0	90	481	245
10	384	0.065	1	5	75	343	147
11	384	0.13	1	5	75	402	157
12	384	0.26	1	5	75	481	167
13	384	0.065	1	10	75	235	108
14	384	0.13	1	10	75	284	118
15	384	0.26	1	10	75	363	128

E.The Effect of Feed Rate on Cutting Force Components

As shown in Fig. 4 (a), (b) and (c); the experiments were performed in different feed rates by a tool which had a constant rake angle ($\alpha=0^\circ$, 5° and 10°) and two different approaching angles ($\lambda=60^\circ$, 75° and 90°). It was observed that when the feed rates were increased, all cutting forces

were increased. For constant approaching angle and rake angle, the cutting forces variations were obtained as shown in Fig. 4 (a), (b) and(c). However, all the cutting forces were increased for the increased feed rates. It is expected that the cutting forces should be increased by the increasing feed rates.

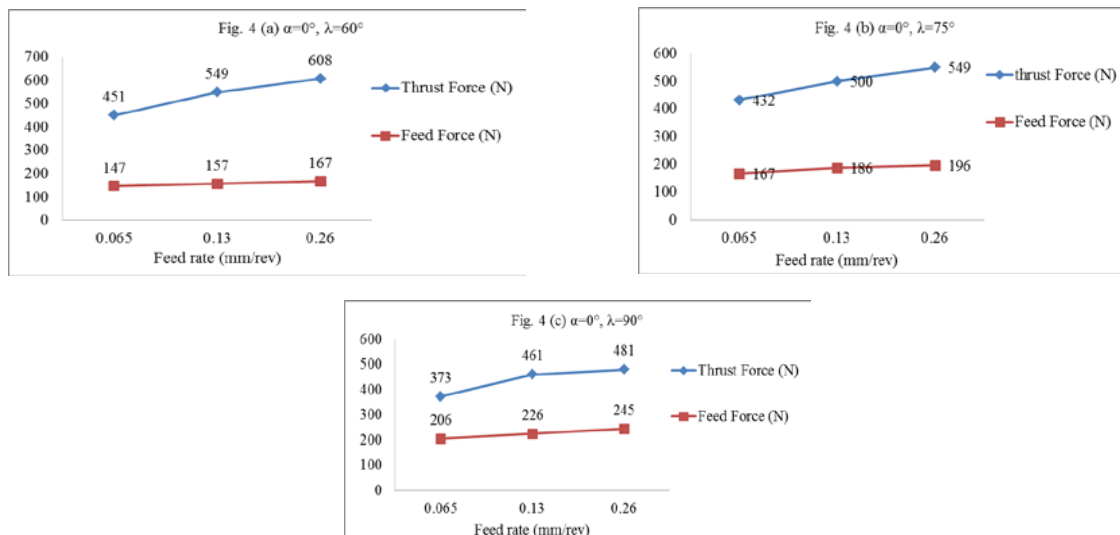

Fig.4 Cutting forces and tool tip temperature change due to the feed rate in different approaching angles

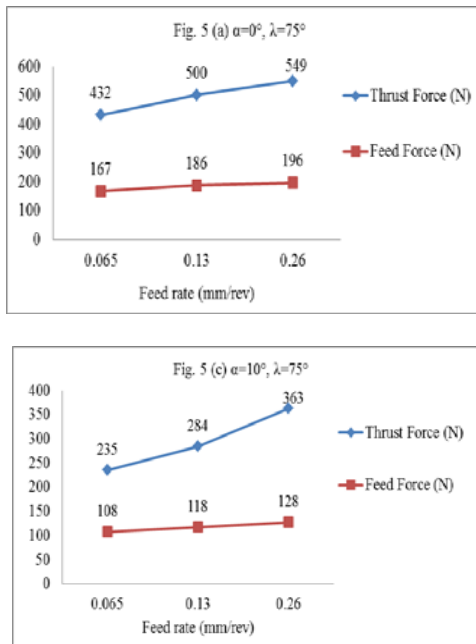

Fig.5 Cutting forces and tool tip temperature change due to the feed rate in different rake angle

IV. CONCLUSION

In this paper a total of 15 experiments were carried on to find the effect of feed rate on the cutting forces during orthogonal turning of EN8 steel using Carbide cutting tool. From the results of this work the following conclusions can be drawn:

1. The results of this study suggest that rake angle have a considerable effect on cutting forces.
2. It was observed that the thrust force (F_t) is greater than the feed force (F_f).
3. It was observed that the thrust force (F_t) and feed force (F_f) increased with increase in feed rates.

REFERENCES

[1] M.E. Merchant. Mechanics of the metal cutting process, ii. Plasticity conditions in orthogonal cutting. Journal of Applied Physics, vol. 16:318-324, 1945.

[2] M. Gunay, E. Aslan, I. Korkut, U. Seker, Investigation of the rake angle on main cutting force, Journal of Machine tools & manufacture.2004, 44, 953-959.

[3] H. Saglam, F. Unsacar, S. Yaldiz, Investigation of the effect of rake angle and approaching angle on main cutting force and tool tip temperature, Journal of Machine tools & manufacture.2006, 46,132-14. technology, new age international(P) limited, publications, Rajender sing 2006

[4] Tugrul O` zel, Tsu-Kong Hsu, Erol Zeren. Effects of cutting edge geometry, workpiece hardness, feed rate and cutting speed on surface roughness and forces in finish turning of hardened AISI H13 steel,

International Journal of Advanced Manufacturing Technology. 2005, 25, 262–269.

[5] A.K. Baldoukas, F.A. Soukatzidis, G.A. Demosthenous, A.E. Lontos. Experimental investigation of the effect of cutting depth, tool rake angle and workpiece material type on the main cutting force during a turning process. Proceedings of the 3rd International Conference on Manufacturing Engineering (ICMEN), 1-3 October 2008

[6] Mustafa Gunay, Ihsan Korkut, Ersan Aslan, Ulvi Seker Experimental investigation of the effect of cutting tool rake angle on main cutting force, Journal of Materials Processing Technology. 2005,166, 44–49.

[7] Haci Saglam, Faruk Unsacar, Suleyman Yaldiz. Investigation of the effect of rake angle and approaching angle on main cutting force and tool tip temperature, International Journal of Machine Tools & Manufacture.2006, 46, 132–141.

[8] D.I. Lalwani, N.K. Mehta, P.K. Jain.. Experimental investigations of cutting parameters influence on cutting forces and surface roughness in finish hard turning of MDN250 steel, journal of materials processing technology.2008, 206, 167–179.

[9] Tugrul O zel, Tsu-Kong Hsu, Erol Zeren. Effects of cutting edge geometry, workpiece hardness, feed rate and cutting speed on surface roughness and forces in finish turning of hardened AISI H13 steel, International Journal of Advanced Manufacturing Technology. 2005, 25, 262–269.

[10] G. Boothroyd, Temperatures in orthogonal metal cutting, Proceedings of Institution of Mechanical Engineering 177 (1963) 623–654.

[11] I. Lazoglu, Y. Altintas, Prediction of tool and chip temperature in continuous and interrupted machining, International Journal of Machine Tools and Manufacture 42 (2002) 1011–1022.

[12] H. Ernst, M.E. Merchant, Chip formation, friction and high quality machined surfaces, Transactions of the ASME 29 (1941) 299–328.

[13] N. Fang a, I.S. Jawahir. Analytical predictions and experimental validation of cutting force ratio, chip thickness, and chip back-flow angle in restricted contact machining using the universal slip-line model, International Journal of Machine Tools & Manufacture.2002, 42, 681–694.

[14] HMT Banglore, “Production technology”, Tata McGraw Hill Education Private Limited, ISBN: 978-0-07-096443-3, 32nd reprint 2011.

[15] P. C. Sharma, “A textbook of production engineering”, S. Chand and Company limited, ISBN: 81-219-0421-8, 2005.

[16] G. R. Nagpal, “Machine tool engineering”, Khanna Publishers, ISBN:81-7409-046-0, 2003.