

Experimental Investigation of Electrohydrodynamic Effect on the Performance of Double Pipe Heat Exchanger

S.V. Kumbhar¹, M.A. Jadhav², A.R. Jadhav³ and S.G. Bardiya⁴

^{1,3&4}Assistant Professor, Department of Mechanical Engineering, S.I.T. College of Engineering, Maharashtra, India

²Assistant Professor, Department of Mechanical Engineering, Bharati Vidyapeeths' College of Engineering, Kolhapur, India
E-Mail: sujit.kumbhar64@sitcoe.org.in, mandarjadhav@sitcoe.org.in, arjmesa@gmail.com, sumit2238@sitcoe.org.in

Abstract - Heat exchanger is a device which transfers heat from one fluid to another fluid. For the improvement in performance of heat exchangers, several heat enhancement techniques have been successfully implemented. These techniques are active, passive and combined techniques. In the active techniques, some external forces, e.g. electric field, acoustic or surface vibration etc. require for heat transfer enhancement. Whereas in the passive techniques, fluid additives or special surface geometries require for heat transfer enhancement. Electrohydrodynamic (EHD) effect can be used to enhance heat transfer rate between two fluids. In this paper, the effect of electrical body force on the performance of double pipe heat exchanger is studied.

Keywords: Electro hydrodynamic (EHD) effect, Dielectric Fluids, Electrical body force

I. INTRODUCTION

In last four decades, the heat transfer enhancement techniques have been implemented tremendously as the size of heat exchanger is continuously decreasing day by day. Any heat exchanger e.g. condenser, evaporator etc. is potential equipment for enhanced heat transfer. Therefore, it is necessary to enhance heat transfer characteristics from existing heat exchanger by several methods. These methods can be categorized as: Active technique and Passive technique. In active technique, application of external force (power) is used to enhance the heat transfer characteristics, such as surface vibration, acoustic or electric fields etc. On the contrary, passive techniques require the application of specific surface geometries with surface augmentation. Both techniques have strong impact on the effectiveness of heat exchangers. There are many factors which determine the effectiveness of heat exchangers *viz.* mode of heat transfer, single phase or multiphase. The heat transfer enhancement can be done either by magnetohydrodynamics (MHD) or electrohydrodynamics (EHD). The MHD method involves the application of strong magnetic field whereas the EHD involves electric field.

II. THEORY OF ELECTROHYDRODYNAMIC (EHD) EFFECT

The electrohydrodynamic (EHD) effect is the effect in which the study of interaction of electric fields and flow fields in a dielectric fluid medium is involved. This interaction of electric field with dielectric fluid medium set

up electrical body force. The general mathematical expression (Landau & Lifshitz) of the electric body force is,

$$f_e = \rho_c E - \frac{1}{2} E^2 \nabla \epsilon + \frac{1}{2} [E^2 \rho \left(\frac{\partial \epsilon}{\partial \rho} \right)_T] \quad (1)$$

Where, ρ_c = electric field space charge density,
 E = applied electric field strength,
 ϵ = dielectric permittivity of the fluid,
 ρ = mass density, and T = temperature.

The first term of right hand side equation (1) represents the Coulomb force which acts on the free charges under the action of electric field. Usually this Coulomb force dominates over remaining two forces under the application of direct current in dielectric fluid medium. The second term of equation represents the dielectrophoretic component force which is due to the spatial change of the permittivity of the dielectric fluid medium as a result of temperature gradients and/or differences. Amongst these, the dielectrophoretic force is weaker than the electrophoretic force as the permittivity of the working fluid is a weak function of the electric field. And the third component represents the electrostrictive component force caused by the inhomogeneous electric field strength and the variation in dielectric constant with density and temperature.

It is seen that Coulomb force has dominant effect, among these forces, in electrohydrodynamics and other two forces are neglected in EHD effect. Therefore, interaction of electric field with dielectric fluid medium can set up a mechanical body force which may be useful in various applications. In this technique, an electric field characterized by a high voltage and low current is applied to the dielectric fluid.

III. EXPERIMENTAL SETUP

The block diagram of experimental setup is shown in Fig1. In this, a double pipe heat exchanger is used as test section. Hot fluid (Water) flows through inner tube and cold fluid (dielectric fluid) flows through annulus region of double pipe heat exchanger.

Two reservoirs of fluids *viz.* hot fluid Water) reservoir and dielectric fluid reservoir are placed on either side of experimental set up. The hot fluid reservoir is provided with heater to heat the fluid. Two electrodes made up of brass, are

immersed in the dielectric fluid and these electrodes are connected to dimmer stat to vary the intensity of electric field in dielectric fluid medium. The heat exchanger has the arrangement for parallel as well as counter flow with four ball valves.

Five thermocouples, with digital temperature indicator, are used to record the temperature at inlet and outlet of hot fluid and cold fluid. The main purpose of secondary heat exchanger is to cool the dielectric fluid and then it is allowed to flow towards dielectric fluid reservoir.

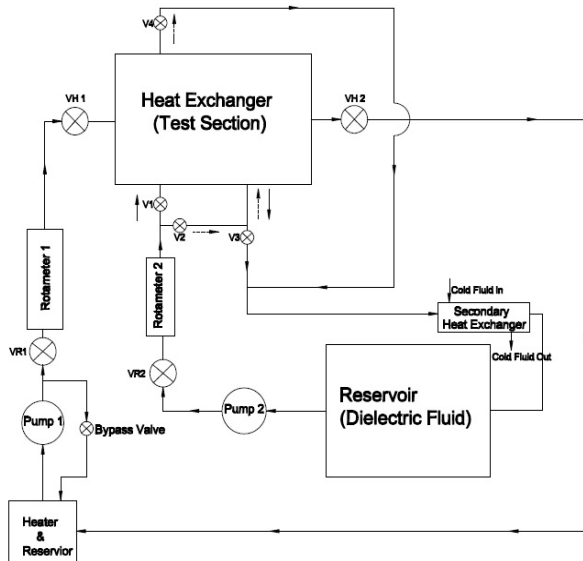

Fig. 1 Block diagram of the experimental setup (Not to scale)

The selection of appropriate materials to conduct and transfer heat at better rate and efficiently is very important criteria in heat exchanger design. In this experiment, the Copper material is selected for inner tube as it is thermally efficient and durable and outer tube is made of M.S. material. The readings are taken for constant mass flow rates and with electrohydrodynamic (EHD) effect.



Fig. 2 Photo of experimental setup

A. Specifications of test loop

1. Length of test section = 700 mm
2. Inner tube diameter = 20 mm
3. Type of thermocouples = PT-100, K-type (5 in Number)
4. Thickness of the test section = 2 mm
5. Heat supplied = up to 3 kW

B. Selection of working fluid

The dielectric fluids are electrical insulator that can be polarized by an applied electric field. Because of dielectric polarization, positive charges are displaced towards the field and negative charges shift in opposite direction. Some practical applications of dielectric fluids are Air, nitrogen, pure water, mineral oils such as transformer oil, castor oil etc. The dielectric fluids, which are chosen for the experimental work, are two: transformer oil and water, which are having widely varying properties. Transformer oil has a low viscosity and an extremely low electrical conductivity. The physical properties of the both working fluids are as follows,

C. Working fluid-I: (Water)

1. Dielectric Breakdown voltage: 74KV
2. Viscosity @ 25C: 10.20 (cSt)
3. Density @ 25C: 1000 Kg/m³
4. Flash point (open cup): > 142°C
5. Specific heat at constant pressure: 4180 J/Kg K

D. Working fluid-II: (Transformer oil)

1. Dielectric Breakdown voltage: 50 KV
2. Viscosity @ 25C: 50 (cSt)
3. Density @ 25C: 960 Kg/m³
4. Flash point (open cup): >300°C/572°F
5. Fire point (open cup): >370°C/698°F
6. Specific heat at constant pressure: 1510 J/Kg K

III. EXPERIMENTATION ON TEST SECTION

In the experimental work, every test has been conducted under constant volumetric flow rate and heat input, with EHD effect. All readings are noted at steady state condition. Both parallel flow and counter flow arrangements are used.

IV. OBSERVATIONS

A. With application of electric field (EHD)

1. Dielectric fluid mass flow rate: Constant
2. Inner tube (Hot water) mass flow rate: constant

TABLE I READINGS FOR PARALLEL FLOW WITH EHD EFFECT

Sr. No.	Applied Voltage to electrode	Inner tube side temperature (Hot side)		Annulus region side temperature (Cold Side)			Current (Amp)
		T ₁ (°C)	T ₂ (°C)	T ₃ (°C)	T ₄ (°C)	T ₅ (°C)	
1	25	39	38	32	33	43	1.58
2	50	41	40	33	35	45	3.27
3	75	43	41	35	36	47	4.97
4	100	45	42	36	37	49	6.6
5	125	47	44	36	38	51	8.26
6	150	49	45	37	39	53	9.92
7	175	50	46	38	41	54	11.59
8	200	51	47	39	43	55	13.17
9	206	53	49	39	43	56	13.67

Readings are taken for the application of EHD effect. The voltage is varied from 25V to 206V for parallel flow arrangement. The heat transfer rate, Overall heat transfer coefficient, heat exchanger effectiveness is calculated for EHD effect. In the same way, readings are noted for counter flow arrangement with EHD effect. Also, heat transfer rate, overall heat transfer coefficient, heat exchanger effectiveness is calculated for EHD effect.

V. CALCULATIONS

As already stated, total electrical body force is the sum of Coulomb force, dielectrophoretic force and electrostrictive force. Among these forces, Coulomb force has dominant effect in electrohydrodynamic. Also, for single phase convective heat transfer application, other two forces are neglected. So equation (1) can be reduced to,

$$f_e = \rho_c E \tag{2}$$

The electrical body can be also given as,

$$f_e = \frac{I \times d}{k} \tag{3}$$

Where I= current (amp), d= distance between two electrodes (m), k=Ion mobility coefficient for dielectric fluid.

VI. RESULTS AND DISCUSSION

From the observations, convective heat transfer coefficient (h), electrical body forces (fe) are calculated under the influence of electric field when fluid flow rate of both fluids are kept constant. A graph of convective heat transfer coefficient (h) against electrical body force (fe) is plotted. From the graph, it is clearly observed that as voltage is increased, the rate of dissociation of molecules is increased.

Hence, the relation between ‘h’ and ‘fe’ is approximately parabolic in nature obtained by fitting a curve.

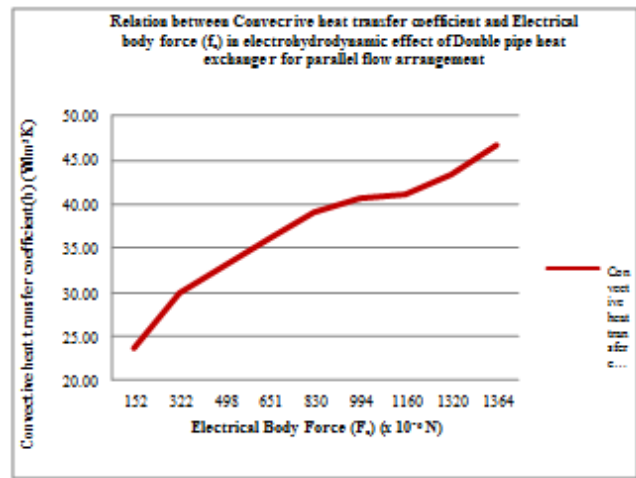

Fig. 3 Variation of electrical body force (fe) v/s convective heat transfer (h)

The approximate mathematical relation between electrical body force (fe) and convective heat transfer (h) is obtained as,

$$y = -6.30 + 0.05707x - (1.0242 \times 10^{-5}) x^2 \tag{4}$$

Where, ‘x’ represents electrical body force in N and ‘y’ represents convective heat transfer coefficient in W/m².

VII. CONCLUSION

From above discussion, it is concluded that as the intensity of electric field increases, heat transfer enhancement is observed. This happens because as the intensity of electric field increases, the dissociation of dielectric fluid molecules increases. Hence, as the rate of dissociation of molecules increases, the electrical body forces increases and consequently, the convective heat transfer increases. This results in enhancement in heat transfer.

REFERENCES

- [1] Akira Yabe, Takao Taketani and Kentaro Kikuchi, "Augmentation method of boiling heat transfer by applying electric fields", Georgia Technical research Corporation, US patent No.US 4471833, Sep 18, 1984.
- [2] R. S. Neve and Y. Y. Yan, "Enhancement of heat exchanger performance using combined electrohydrodynamic and passive methods", *Int. J. Heat and Fluid Flow*, Vol. 17, pp. 403-409, 15 January 1996.
- [3] C. C. Pascual, "A statistical analysis of EHD-enhanced nucleate boiling along a heated wire", *International Journal of Heat and Mass Transfer*, Vol. 44, pp. 1201-1212, 2 September 1999, 2001.
- [4] Muraki M, T Sano and Dong D., "Rheological properties of polyster under an EHD contact in some refrigerant environments", *Journal of Tribology*, Vol. 123, No. 1, pp. 54-60, 2001.
- [5] Jamal Seyed-Yagoobi and Markus Wawzyniak, "Electrohydrodynamic induction pumping thermal heat transfer system and method", The Texas A & M, University system, US patent No. US 6409975, 25 June, 2002.
- [6] Dariusz Butrymowicz, Marian Trela and Jarosław Karwacki "Enhancement of condensation heat transfer by means of EHD condensate drainage", *Int. J. Therm. Sci.* Vol. 41, pp. 646-657, 8 February 2002.
- [7] A. Al-Ahmadi and R.K. Al-Dadah "A new set of correlations for EHD enhanced condensation heat transfer of tubular systems", *Applied Thermal Engineering*, Vol. 22, pp. 1981-2001, 29 August 2002.
- [8] Walter Grassi, "EHD enhanced heat transfer in a vertical annulus" *International Communications in Heat and Mass transfer*, Vol. 32, pp. 748-757, 17 March, 2005.
- [9] Jamal Seyed-Yagoobi, "Electrohydrodynamic pumping of dielectric liquids", *Journal of Electrostatics*, Vol. 63, pp. 861-869, 19 March 2005.
- [10] H. Sadek, A.J. Robinson and J.S. Cotton, C.Y. Ching, M. Shoukri, "Electrohydrodynamic enhancement of in-tube convective condensation heat transfer", *International Journal of Heat and Mass Transfer* Vol. 49, pp. 1647-1657, 4 January 2006.
- [11] Hamid Omiddvarborna and Arjomand Mehrabani-Zeinabad, "Effect of electrohydrodynamic (EHD) on condensation of R-134a in presence of non-condensable gas", *International Communications in Heat and Mass Transfer*, Vol. 36, pp. 286-291, 2017 December 2008.
- [12] Sid'Ahmed ould Ahmedou and Michel Havet, "Effect of process parameters on the EHD airflow", *Journal of Electrostatics*, Vol. 67, pp. 222-227, 15 February 2009.
- [13] R. Gharraei and E. Esmaeilzadeh, "Experimental investigation of electrohydrodynamic conduction pumping of various liquids film using flush electrodes", *Journal of electrostatics*, Vol. 69, pp. 43-53, 2011.
- [14] S.W. Ahmad, T.G. Karayiannis, D.B.R. Kenning and A. Luke, "Compound effect of EHD and surface roughness in pool boiling and CHF with R-123", *Applied Thermal Engineering*, Vol. 31, 1994-2003, 24 March 2011.
- [15] Matthew R. Pearson and Jamal Seyed-Yagoobi, "Experimental study of EHD conduction pumping at the meso- and micro-scale", *Journal of Electrostatics*, Vol. 69, 2011, pp. 479-485, 24 August 2011.
- [16] J.S. Cotton, A.J. Robinson, M. Shoukri and J.S. Chang, "AC voltage induced electrohydrodynamic two-phase convective boiling heat transfer in horizontal annular channels", *Experimental Thermal and Fluid Science*, Vol. 41, pp. 31-42, 14 March 2012.
- [17] Marcelo Marucho and Antonio Campo, "Electrohydrodynamic natural convection enhancement for horizontal axisymmetric bodies", *International Journal of Thermal Sciences*, Vol. 63, pp. 22-3029 August 2012.
- [18] Nader Nourdanesh and Esmaeil Esmaeilzadeh "Experimental study of heat transfer enhancement in electrohydrodynamic conduction pumping of liquid film using flush electrodes", *Applied Thermal Engineering*, Vol. 50, pp. 327-333, 2013.
- [19] L. Léal, M. Miscevic, P. Lavieille, M. Amokrane, F. Pigache, F. Topin and B. Nogarède L. Tadrist, "An overview of heat transfer enhancement methods and new perspectives: Focus on active methods using electroactive materials", *International Journal of Heat and Mass Transfer* Vol. 61, pp. 505-524, 8 March 2013.
- [20] R. Naresh and J. M. Babu, "Electrohydrodynamic enhancement of heat transfer by different working fluids in a forced convection loop", *International Journal of Engineering and Advanced Technology (IJEAT)*, ISSN: 2249-8958, Vol. 0-3, 2 December 2013.
- [21] S. V. Kumbhar and H. M. Dange, "Performance analysis of Double pipe heat exchanger for electrohydrodynamic (EHD) effect", *Indian Journal of Scientific Research and Development*, Vol. 3, No. 3, pp. 734-739, ISSN (online): 2321-0613, 2015.
- [22] N S Mane and H M Dange, "A Review on use of Magnetic Effect in Refrigeration and Air Conditioning", *International Journal for Scientific Research & Development*, Vol. 2, No.12, 2015.